

EP500



USER GUIDE

SW : 5.22
ENGLISH

OPERATING INSTRUCTIONS

EP500 control unit can be used to control one single-phase 230V_{AC} motor up to 800W or one three-phase 400V_{AC} motor up to 1,5kW.

Instructions:

- Cable connections and the operating logic should be in compliance with regulations.
- The cables with different voltages should be kept detached or adequately insulated by an additional insulation of at least 1mm.
- Cables should be connected to terminals properly without exposed metal surface outside of terminals.
- Check all connections before powering the unit.
- **Normally Close (NC) inputs** which are not used should be short-circuited to **COM**.
- The power supply mains should be connected to an omni polar switch with contact opening distance minimum 3mm. Check that upstream electric system is provided with an adequate differential switch and overcurrent switch.
- Unless supervised or instructed, this device is not intended to be used by individuals with low physical, sensory or mental abilities (included children) or those lacking experience and knowledge.
- Children should be supervised to prevent them from playing with the device.
- Keep remote controls out of reach of children.
- Device is suitable for use at altitudes above 2000 meters.
- Inspect the installation for possible imbalance and signs of wear or damage in cables, springs and assembly. Do not use if repair or adjustment is necessary.
- Disconnect the power supply when cleaning or performing other maintenance.
- Installation instructions specify the type, size and mass of the driven part as well as locations where the controller unit can be mounted and whether the drive is suitable only for balanced vertically driven components.
- Before installing the controller unit, check that the driven part is properly balanced and suitable.
- After installation, make sure that the mechanism is properly adjusted.



WARNING:

Follow all instructions carefully as improper installation may result in serious injury.



WARNING:

Control unit must be disconnected from power supply during cleaning, maintenance and replacement of parts.

Can only be connected by qualified and trained electrical technicians.

Program the control unit and finish installation.

Qualified and trained electrical technicians are expected to meet the following requirements:

- Knowing and applying general and special safety and accident prevention regulations
- Knowledge of relevant electrical regulations
- Trained in the use and maintenance of appropriate safety equipment
- Recognizing electrical hazards

NOTE:

EP500 control unit does not contain substances such as Asbestos, PCB (Polychlorinated Biphenyl) and HG (Mercury) that are harmful to human health and is not used in its production.

OVERVIEW

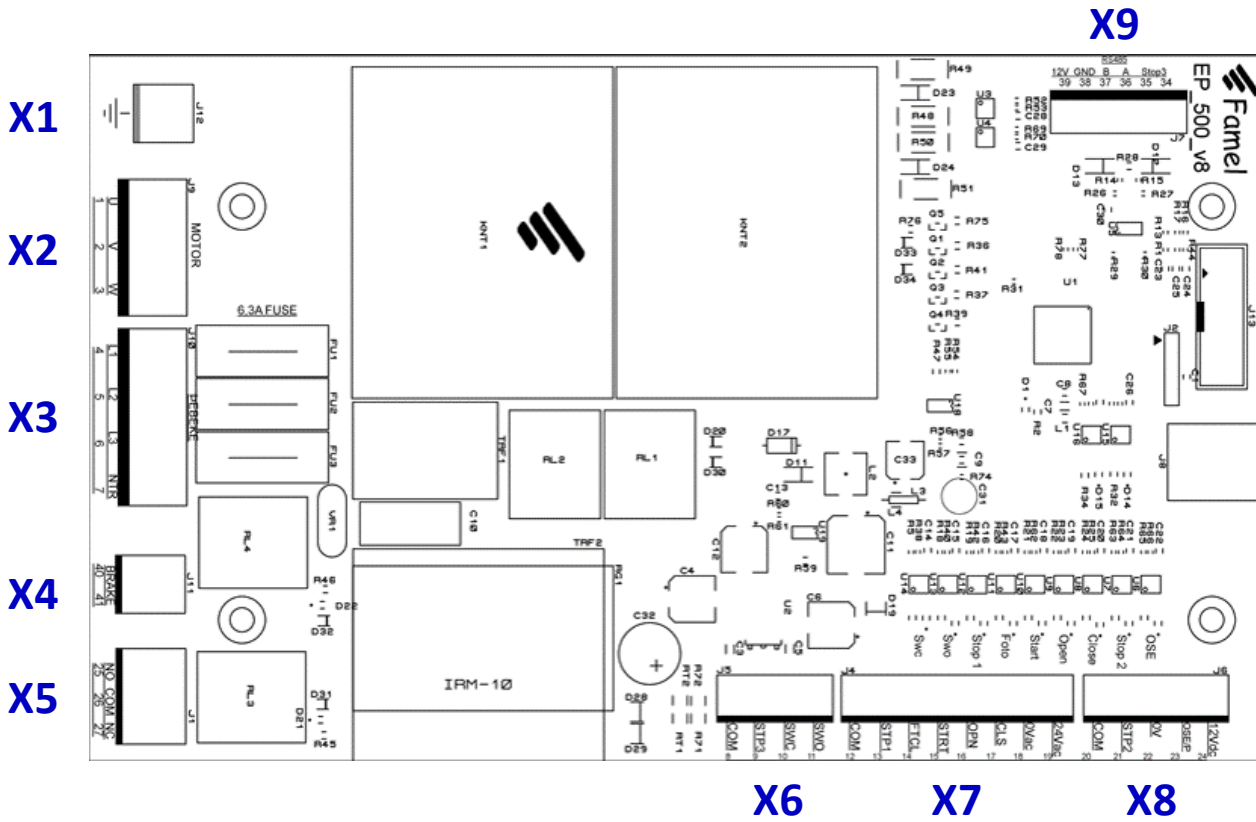

X1 – EARTH CONNECTION TERMINAL

X2 – MOTOR CONNECTION TERMINAL

Pin	Function	Description
1	U	400VAC three-phase motor connection
2	V	
3	W	

X3 – MAINS SUPPLY TERMINAL

Pin	Function	Description
4	L1	Three-phase grid connection (400VAC 50Hz)
5	L2	
6	L3	
7	N	Neutral

X4 – BRAKE CONNECTION TERMINAL

Pin	Function	Description
40	~	230VAC motor brake connection
41	~	

X5 – PROGRAMMABLE RELAY OUTPUT TERMINAL

Pin	Function	Description
25	NO	Programmable relay NO contact
26	COM	Programmable relay COM contact
27	NC	Programmable relay NC contact

X6 – LIMIT SWITCH TERMINAL

Pin	Function	Description
8	COM	Common connection
9	STP3	Emergency stop 3 connection terminal (motor thermic and manual switch)
10	SWC	Close limit switch connection
11	SWO	Open limit switch connection

X7 – COMMAND AND SECURITY DEVICES CONNECTION TERMINAL

Pin	Function	Description
12	COM	Common connection
13	STP1	Emergency Stop 1 connection (NC contact)
14	FTCL	Photocell connection (NC contact)
15	STRT	Start button connection (NO contact)
16	OPN	Open button connection (NO contact)
17	CLS	Close button connection (NO contact)
18	0VAC	24VAC output (max. 350mA)
19	24VAC	

X8 – OPTOELECTRICAL SAFETY EDGE TERMINAL

Pin	Function	Description
20	COM	Common connection
21	STP2	Stop input for pedestrian door connection (NC contact)
22	GND	Power supply GND for optical sensor
23	OSE/P	Safety edge signal connection
24	12Vdc	Power supply 12Vdc for optical sensor

X9 – ELECTRONICAL LIMIT SWITCH TERMINAL

Pin	Function	Description
34	COM	Common connection
35	STP3	Emergency Stop 3 connection (NC contact)
36	A	ENC RS485A connection
37	B	ENC RS485B connection
38	GND	Power supply for ENC
39	12V+	

CONNECTIONS

X2 - Motor Connection

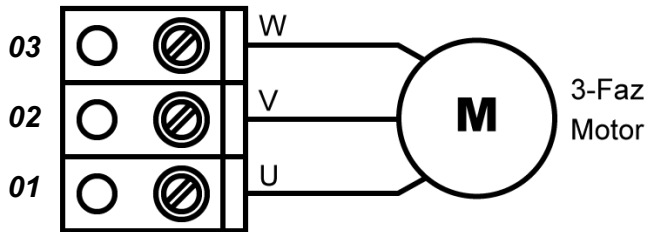

Connect three-phase motor to the **U(1)**, **V(2)** and **W(3)** terminals shown in the figure.

X3 - Mains Supply Connection

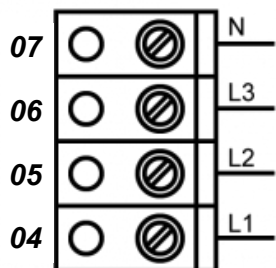

Make the power connection of the control unit from **L1(04)**, **L2(05)**, **L3 (06)** and **N(07)** terminals as shown in the figure. Input supply voltage is 3N~400VAC-50Hz.

X5 - Programmable Relay Connection

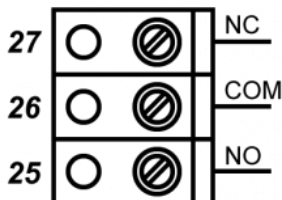

Programmable relay output terminal is shown in the figure. Different options are offered for the use of this terminal. It can be programmed as flasher, traffic light, door opened, door closed, buzzer etc. output from menu number 504.

X6 - Limit Switch Connection

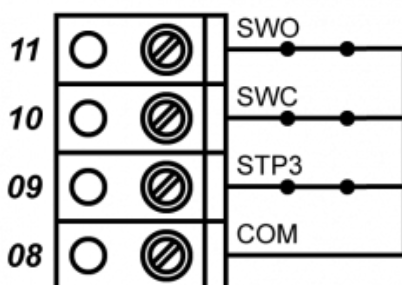

If a door drive with a mechanical limit switch is used, the stop cable coming from the motor must be connected to **STP3 (9)** terminal. Similarly, the closing limit-switch cable must be connected to the **SWC(10)** and the opening limit-switch cable must be connected to **SWO(11)** terminals. Unused terminals must be connected to **COM(8)** terminal.

NOTE: Cables which are suitable for door drive comes pre connected in the door drive box. Unplug appropriate terminal from control unit and plug relevant end of the cable to appropriate terminal. Use terminal **X9** for **ENC** or **X6** for **MEC**.

X7 - Command and Security Devices Connection

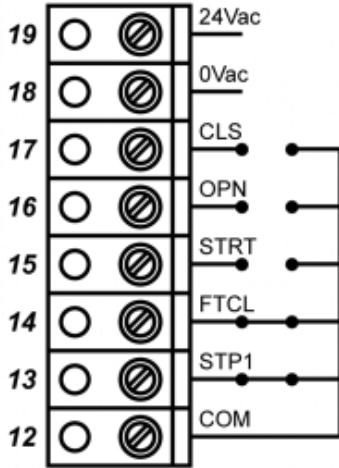

Connections of command and safety devices are shown on the left.

You can give a STOP command to the door by connecting a NC contact button to the **STP1(13)** terminal. If this input will not be used, it must be connected to **COM(12)**.

You can connect your photocell output to the **FTCL(14)** terminal. Photocell can be powered with using **24VAC** power supply output (terminals **18** and **19**). If a photocell is not used, this input should be connected to **COM(12)**.

You can command the door to START by connecting a button to **STRT (15)** terminal. By default, it operates in the OPEN-STOP-CLOSE-STOP sequence. If this input will not be used, it should be left blank.

You can command the door to OPEN by connecting a button to **OPN**

(16) terminal. If this input will not be used, it should be left blank.

You can command the door to CLOSE by connecting a button to **CLS(17)** terminal. If this input will not be used, it should be left blank.

X8 - Optoelectronic Safety Edge Connection

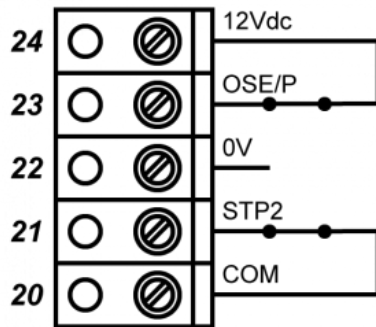

STP2(21) can be programmed as either HALF-OPEN or PEDESTRIAN door switch (default). If this input will not be used, it should be connected to **COM(20)**.

If pneumatic is to be connected to the door, it must be connected to the **OSE/P(23)** terminal. This input can be used as NO or NC. If not used, it must be connected to **+12V(24)** terminal.

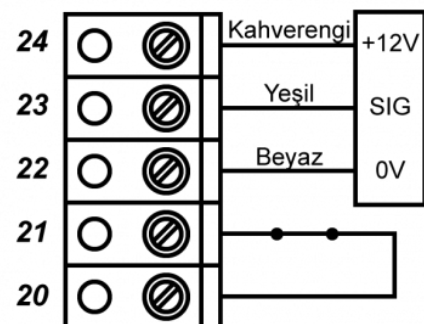

If an optosensor will be connected to the door, **+12V(24)** and **GND (22)** terminals should be used for the supply voltage of the sensor. The sensor output must be connected **OSE/P (23)** terminal. This input programmed to respond to signals at a frequency of 100kHz.

**To program the entry, see menu 503.*

X9 - Electrical Limit Switch Connection

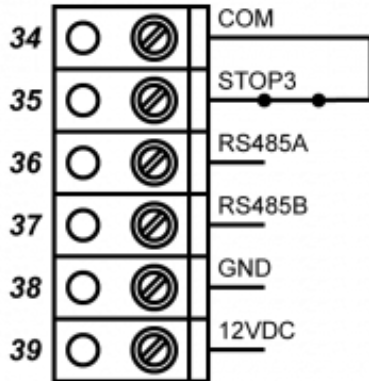

EP500 control unit is compatible with ENC (electronic limit switch). Use **12V+(39)** and **GND(38)** terminals for ENC supply voltage. Also use RS485 **B(37)** and **A(36)** terminals for communication. Finally, you need to connect the ENC safety input and output to **STP3(35)** and **COM(34)** terminals. Inf ENC will not be used, **STP3(35)** must be connected to **COM(34)**.

NOTE: Cables which are suitable for door drive comes pre connected in the door drive box. Unplug appropriate terminal from control unit and plug relevant end of the cable to appropriate terminal. Use terminal **X9** for **ENC** or **X6** for **MEC**.

Programming with LCD Information Display

Various functions of the control unit can be programmed using LCD information screen located on the front of the unit and setting the necessary parameters in the programming menu as described below.

PARAMETERS ADJUSTMENT MENU, allows editing values of relevant functions.

LOJIC ADJUSTMENT MENU, allows to turn on-off relevant functions.

Special functions follow *PARAMETERS ADJUSTMENT MENU* or *LOJIC ADJUSTMENT MENU* and may vary depending on the type of controller or software version.

Access to the Programming Menu:

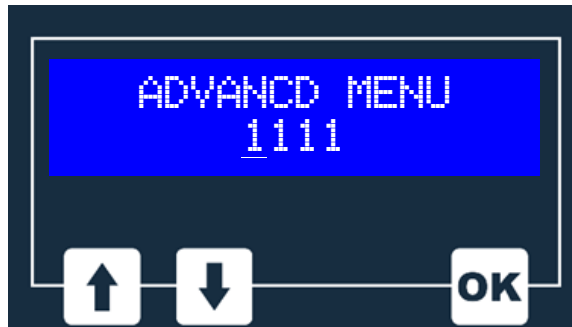

1. Press and hold **UP** and **DOWN** buttons at the same time, password screen will appear on the screen.
2. To enter the password, use **UP** and **DOWN** buttons. For changing position of cursor, use **OK** button. (Default password is 1453)
3. Navigate to desired menu using **UP**, **DOWN** and **OK** buttons.

1-PARAMETERS ADJUSTMENT	2-LOJIC ADJUSTMENT
3- END POSITION ADJUSTMENT	4-DOOR WORKING INFORMATION
5-INPUT-OUTPUT ADJUSTMENTS	6-LCD ADJUSTMENTS

Note: After a 60-second waiting period, control unit exits programming mode and programming menu will disappear.

**1-PARAMETERS
ADJUSTMENT**

100.AUTO. CLOSING TIME: 40 SEC	Automatic close time. After countdown, control unit closes door.
101.MAX. OPEN TIME: 30 SEC	Maximum opening time. This parameter restricts maximum elapsed time on opening direction.
102.MAX. CLOSE TIME: 30 SEC	Maximum closing time. This parameter limits maximum elapsed time on closing direction.
103.FOREWARN. OPN TIME: 2 SEC	Before the door starts to move upwards, if the pre-warning mode is activated flasher will be on for pre-warning period.
104.FOREWARN. CLS TIME: 5 SEC	Before the door starts to move downwards, if the pre-warning mode is activated flasher will be on for pre-warning period.
105.FAST CLOSE TIME: 5 SEC	Fast close time. After the door opened, photocell detects passage and changes automatic closing time to set value. It must be activated from logic menü.
106.TURNAROUND TIME: 200MS	Waiting time at the change of direction.
107.MAX CURRENT 4.0AMP	Motor overcurrent protection value.
110.PART. OPENING TIME: 5 SEC	Half-opening time.

2-LOGIC
ADJUSTMENT

200. AUTO. CLOSING OFF	Parameter to set automatic shutdown mode enable/disable
201. BLOCK PULSES OFF	Sets whether the START (Step-by-Step) signal or CLOSE button signal will be effective or not during opening phase.
202. FAST CLOSE OFF	Enable/disable status setting for quick shutdown mode.
203. WORKING MODE OP. AUTO/CLS. AUTO	<ol style="list-style-type: none"> 1. Open Auto/Close Auto 2. Open Auto/Close Manual 3. Open Manual/Close Manual
204. 3 / 4 STEP OP/STOP/CLS/STOP	<ol style="list-style-type: none"> 1. Open/Stop/Close/Stop 2. Open/Stop/Close/Open
205. PRE-ALARM OFF	Enable/disable status setting for pre-warning mode.
206. SPRING COUNT OFF	Spring life counter enable/disable setting.
207. GATE-CYCLE OFF	Service warning counter enable/disable setting.
208. SERVICE MODE OFF	Service mode enable/disable setting.
209. MENU PASSWRD ON	Menu password enable/disable setting.
210. PHASE DETECT ON	Phase control enable/disable setting.
211. OVER CURRENT ON	Overcurrent protection enable/disable setting.

3- END POSITION ADJUSTMENT

300.OPEN ENDPOS.
5000

Click **OK** button to set open limit position.

300.OPEN ENDPOS.
5000 4000

Press **OPEN** button to set opened position and press **OK** button to save.

Set Value

Actual Value

301.CLOSE ENDPOS
3000

Click **OK** button to set close limit position.

301.CLOSE ENDPOS
3000 4000

Press **CLOSE** button to set closed position and press **OK** button to save.

Set Value

Actual Value

302.FINE ADJ.OPEN

Calibration value for open limit.

303.FINE ADJ.CLOS

Calibration value for close limit.

304.ABSL.ENCODER
OFF

Absolute encoder ON/OFF setting.

305.REVERSE OFF
VALUE: 150

Cancellation position of safety edge systems for closing direction (distance value from close limit value).

306.ROTATINGFIELD
MOD 1: STRAIGHT

Mod 1: Straight
Mod 2: Reverse

4-DOOR WORKING
INFORMATION

<p>400.TOTAL CYCLE COUNT: 0</p>	<p>Total cycle counter.</p>
<p>401.SERVICE WARN COUNT: 20000</p>	<p>Service warning value for cycle counter.</p>
<p>402.SPRING WARN. COUNT: 20000</p>	<p>Spring warning value for cycle counter.</p>
<p>403.PRODUC. DATE 21.11.2018</p>	<p>Production date.</p>
<p>404.MOUNT. DATE 09.01.2019</p>	<p>Installation date.</p>
<p>405.SERIAL NUMB. 19010924124001</p>	<p>Product serial number.</p>

5-INPUT-OUTPUT ADJUSTMENTS

500.INPUT10 SWC ON	Menu for setting closed limit switch input ON/OFF.
501.INPUT11 SWO ON	Menu for setting opened limit switch input ON/OFF
502.INPUT 21 PED. DOOR SWITCH	1.Pedestrian door switch 2.pedestrian open
503.INPUT 23 OSE 2.PNEUMATIC NC	1.Optosensor 2.Pneumatic NC 3.Pneumatic NO
504.RELAY25-26-27 MOD1.FLASOR	1.Flasher 4.Opening 7.Closed 10.Closing+Closed 2.Buzzer 5.Closing 8.Opened+Closed 11.Opening+Closed 3.Error 6.Opened 9.Opening+Opened 12.Closing+Opened
505.RELAY28.29.30 MOD1.FLASOR	1.Flasher 4.Opening 7.Closed 10.Closing+Closed 2.Buzzer 5.Closing 8.Opened+Closed 11.Opening+Closed 3.Error 6.Opened 9.Opening+Opened 12.Closing+Opened
506.FACTORY DEF. 2.END.ENCODERLI	1.Endust.M.SW. 2.End.Encoder 3.H.PVC M.Switch 4. H.PVC Encoder 5.Factory Reset
PC COMMUNICATION WAITING	Communication menu between control unit and computer

6-LCD ADJUSTMENTS

600-LANGUAGE
1. TURKISH

Language selection menu.
1.Turkish 2.English

601.MENU PASSWORD

Password change menu.

602ERROR HISTORY

Error history menu.

FAULT MESSAGES

<p>EP500A POWER ERROR</p>	<p>Phase sequence is incorrect. Check phase sequence or fuses.</p>
<p>EP500A MOT. POWER ERROR</p>	<p>Check motor connection cables or motor.</p>
<p>EP500A EMERGENCY STOP1</p>	<p>Check emergency stop button or emergency button cables.</p>
<p>EP500A EMERGENCY STOP3</p>	<p>Check motor temperature, it I caused due to thermic switch or manual emergency operator.</p>
<p>EP500A ENCODER ERROR</p>	<p>Electronic limit switch communication error. Check ENC connection.</p>
<p>EP500A PED. DOOR OPEN</p>	<p>Check connection of STOP2 input.</p>
<p>EP500A MOTOR DIR. ERROR</p>	<p>Motor direction error. Change two cables of motor.</p>



SBR
— ENGINEERING

Address:

Fevziçakmak Mah. Sila Cad.

48-O, Elit Sanayi Sitesi,

Karatay / KONYA

Phone : +90 850 533 1727

Fax : +90 332 238 4182

Mail : info@sbr.com.tr

Web : www.sbr.com.tr