

# TECHNICAL PRODUCT CATALOG

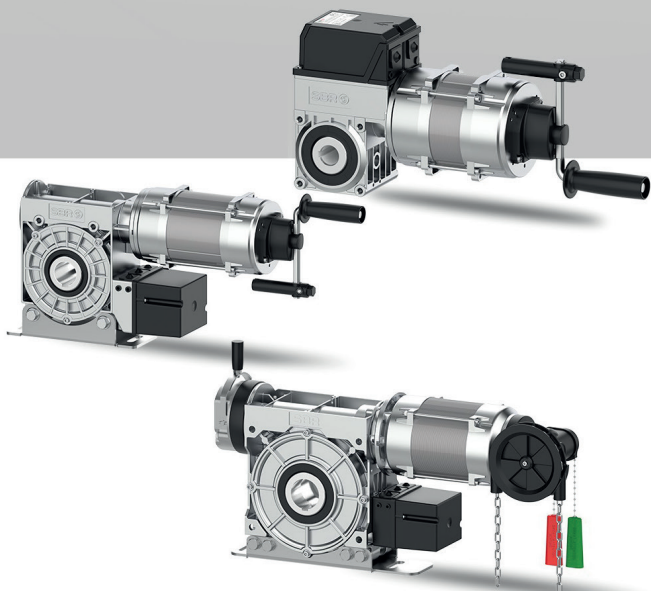
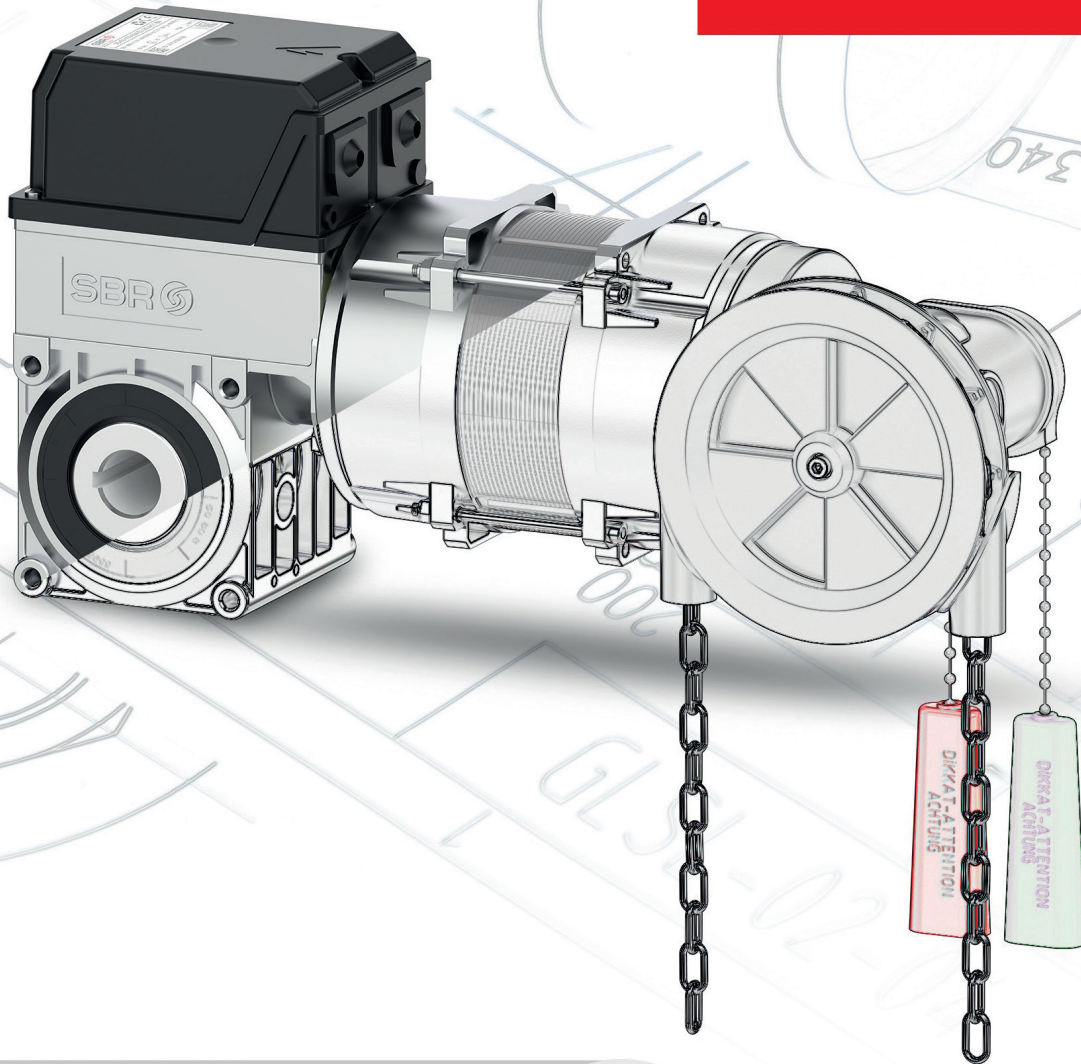

**SBR**  
— ENGINEERING

<b>ID</b>	<b>ITEM DESCRIPTION</b>	<b>3</b>
<b>SD</b>	<b>SPRING-BALANCED SECTIONAL DOORS DRIVES</b>	<b>6</b>
<b>DS</b>	<b>NON BALANCED SECTIONAL DOORS DRIVES</b>	<b>10</b>
<b>RD</b>	<b>ROLLER SHUTTER DOORS DRIVES</b>	<b>18</b>
<b>PS</b>	<b>HIGH SPEED DOORS DRIVES</b>	<b>27</b>
<b>KD</b>	<b>CHAIN TRANSMISSION DOORS DRIVES</b>	<b>35</b>
<b>CU</b>	<b>CONTROL UNIT</b>	<b>43</b>

## ITEM DESCRIPTION

① SD - ② 050 - 0100 - 048 - ③ D25.4 - ④ E20 - 0.75KW - ⑤ 3N400 - C2 - B2 - ⑥ FI

### OUTPUT SHAFT

<b>D25.0</b>	Ø25.0 mm
<b>D25.4</b>	Ø25.4 mm
<b>D30.0</b>	Ø30.0 mm
<b>D31.75</b>	Ø31.75 mm
<b>D40.0</b>	Ø40.0 mm
<b>D55.0</b>	Ø55.0 mm

### OUTPUT SPEED

<b>010</b>	10 rpm
<b>015</b>	15 rpm
<b>024</b>	24 rpm
<b>048</b>	48 rpm
<b>140</b>	140 rpm

### OUTPUT TORQUE

<b>0060</b>	60 Nm
<b>0080</b>	80 Nm
<b>0100</b>	100 Nm
<b>0120</b>	120 Nm

### BODY SIZE

<b>050</b>	50 TYPE BODY
<b>063</b>	63 TYPE BODY
<b>085</b>	85 TYPE BODY
<b>110</b>	110 TYPE BODY

### LIMIT SWITCH

<b>E15</b>	ELECTRONIC LIMIT SWITCH
<b>E20</b>	ELECTRONIC LIMIT SWITCH
<b>M15</b>	MECHANIC LIMIT SWITCH
<b>M20</b>	MECHANIC LIMIT SWITCH

### PRODUCT GROUP

<b>SD</b>	SECTIONAL DOOR DRIVES
<b>DS</b>	NON BALANCED SECTIONAL DOOR DRIVES
<b>RD</b>	ROLLER SHUTTER DOOR DRIVES
<b>PS</b>	HIGH SPEED DOOR DRIVES
<b>KD</b>	CHAIN DRIVE DOOR DRIVES

### MOTOR POWER

<b>0.37KW</b>	0,37 kW MOTOR
<b>0.55KW</b>	0,55 kW MOTOR
<b>0.75KW</b>	0,75 kW MOTOR
<b>1.10KW</b>	1,10 kW MOTOR
<b>1.50KW</b>	1,50 kW MOTOR
<b>2.20KW</b>	2,20 kW MOTOR
<b>3.00KW</b>	3,00 kW MOTOR

### EXTRA FEATURE

<b>FI</b>	FREQUENCY INVERTER
<b>HD</b>	REFRIGERATED BODY

### BRAKE

<b>B0</b>	NON BRAKE
<b>B1</b>	5 Nm BRAKE
<b>B2</b>	10 Nm BRAKE
<b>B3</b>	20 Nm BRAKE
<b>R1</b>	5 Nm FRONT BRAKE
<b>R2</b>	10 Nm FRONT BRAKE

### EMERGENCY OPERATION

<b>C1</b>	HAND CHAIN OPERATOR C1
<b>C2</b>	HAND CHAIN OPERATOR C2
<b>C3</b>	HAND CHAIN OPERATOR C3
<b>MK</b>	HAND CRANK
<b>RK</b>	RELEASE CRANK

### OPERATING VOLTAGE



<b>1N230</b>	1N~230 V
<b>3N400</b>	3N~400 V

## ITEM DESCRIPTION

### 1-PRODUCT GROUP

		Output Torque (Nm)	Output Speed (rpm)
<b>SD</b>	SECTIONAL DOOR DRIVES	80-140	15-80
<b>DS</b>	NON BALANCED SECTIONAL DOOR DRIVES	140-1000	15-24
<b>RD</b>	ROLLER SHUTTER DOOR DRIVES	130-1800	10-15
<b>PS</b>	HIGH SPEED PVC DOOR DRIVES	40-250	35-140
<b>KD</b>	CHAIN DRIVE DOOR DRIVES	100-1000	24

### 2- BODY SIZE

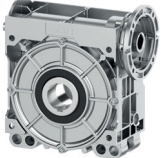
<b>50</b>	GEARBOX 50	
<b>63</b>	GEARBOX 63	
<b>85</b>	GEARBOX 85	
<b>110</b>	GEARBOX 110	

### 3- OUTPUT SHAFT

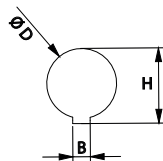
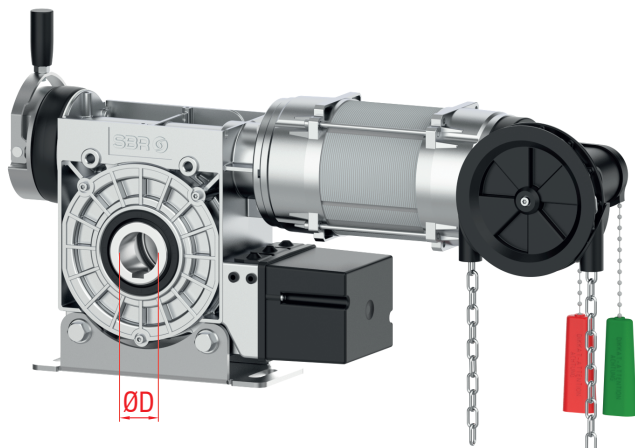



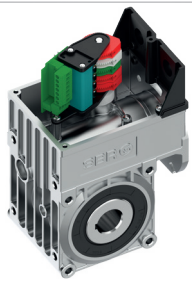

ØD	H	B
<b>D25.0</b>	28,3	8,00
<b>D25.4</b>	28,4	6,35
<b>D30.0</b>	33,3	8,00
<b>D31.75</b>	34,7	6,35
<b>D40.0</b>	43,3	12,00
<b>D55.0</b>	64,4	16,00

## ITEM DESCRIPTION

### 4- LIMIT SWITCH

<p>E15 E20</p>	<p>ELECTRONIC LIMIT SWITCH</p>	 A square-shaped metal limit switch with a black top cover and a circular opening on the front face.
<p>M15 M20</p>	<p>MECHANIC LIMIT SWITCH</p>	 A square-shaped metal limit switch with a black top cover and a circular opening on the front face, featuring a green and red mechanical actuator on top.

### 5-EMERGENCY OPERATION

<p>C1</p>	<p>C1 RAPID HAND CHAIN OPERATOR</p>	 A black hand chain operator with a red and green handle and a chain.
<p>C2</p>	<p>C2 HAND CHAIN OPERATOR</p>	 A black hand chain operator with a red and green handle and a chain.
<p>C3</p>	<p>C3 HAND CHAIN OPERATOR</p>	 A black hand chain operator with a red and green handle and a chain.
<p>MK</p>	<p>HAND CRANK</p>	 A black hand crank with a T-shaped handle.
<p>RK</p>	<p>RELEASE CRANK</p>	 A black release crank with a red and green handle and a chain.

# SD SERIES

# SPRING-BALANCED SECTIONAL DOORS DRIVES



		SD-50-100-24	SD-50-100-30	SD-50-110-24	SD-50-130-15	SD-50-120-20	SD-50-140-20	SD-50-80-30-FI	SD-50-100-48-FI
--	--	--------------	--------------	--------------	--------------	--------------	--------------	----------------	-----------------

## Mechanical Properties

		SD-50-100-24	SD-50-100-30	SD-50-110-24	SD-50-130-15	SD-50-120-20	SD-50-140-20	SD-50-80-30-FI	SD-50-100-48-FI
Output Torque	Nm	100	100	110	130	120	140	80	100
Output Speed	rpm	24	30	24	15	20	20	15-45	15-80
Output Shaft <sup>1</sup>	mm	25,4	25,4	25,4	25,4 31,75	25,4 31,75	25,4 31,75	25,4	25,4 31,75
Max. Cycles Per Hour <sup>2</sup>	h	12	14	10	10	8	8	25	20
Limit Switch Range	rev	20	20	20	20	20	20	20	20
Max. Output Speed OPEN / CLOSE For Frequency Inverter Operation	rpm	42 / 30	52 / 30	42 / 30	26 / 20	34 / 30	34 / 30	--	--
Door Size <sup>3</sup>	m <sup>2</sup>	30	30	45	45	50	50	30	45

## Electrical Properties

		SD-50-100-24	SD-50-100-30	SD-50-110-24	SD-50-130-15	SD-50-120-20	SD-50-140-20	SD-50-80-30-FI	SD-50-100-48-FI
Motor Power	KW	0,37	0,55	0,55	0,37	0,37	0,55	0,55	0,75
Operating Voltage	V	3N~400	3N~400	3N~400	3N~400	3N~400	3N~400	1N~230	1N~230
Operating Frequency	Hz	50/60	50/60	50/60	50/60	50/60	50/60	50	50
Operating Current <sup>4</sup>	A	2,7/1,6	3,8/2,2	3,8/2,2	2,3/1,3	1,8/1,1	3,9/2,3	5,0	6,0
Fuse Protection, On Site	A	10	10	10	10	10	10	10	10
Duty Types	ED	S3-%60	S3-%60	S3-%60	S3-%60	S3-%60	S3-%60	S3-%60	S3-%60
IP Protection Class	IP	54	54	54	54	54	54	54	54
Temperature Range <sup>5</sup>	°C	-20 40 (+60)	-20 +40 (+60)	-20 40 (+60)	-20 +40 (+60)	-20 +40 (+60)	-20 40 (+60)	-20 +40 (+60)	-20 +40 (+60)
Working Noise Level	dB (A)	< 70	< 70	< 70	< 70	< 70	< 70	< 70	< 70

1- Output shafts Ø25,0-Ø25,4-Ø30,0-Ø31,75-Ø40,0 mm etc. can be made upon request.

2- One cycle corresponds to two door movements (opening and closing). The specified values represent 10 revolutions of the drive shaft per movement and an even distribution is assumed. Other limit speed ranges, ambient temperature and extra friction affect the value.

3- The values in the table take into account a weight of 13 kg/m<sup>2</sup> and assume full spring balance. In some cases the friction may be greater and this must be taken into account when calculating the values.

4- The current in door drives can reach up to 4 times the rated operating current for limited times.

5- Allowable temperature -20°C..+40°C (+60°C). When using the +40°C..+60°C temperature range, half of the maximum movements per hour should be used.

↘ If frequency inverter drives are used, increasing the driving speed by 10% will cause a 5% decrease in drive torque. This should be considered when choosing a driver.

↘ In gearmotors powered at a frequency of 60Hz (and at the same voltage), multipliers are used for some performance figures: Output torque: 0,83, and rotations in output: 1,2

# DIMENSIONS

## SD-50 WITH C1

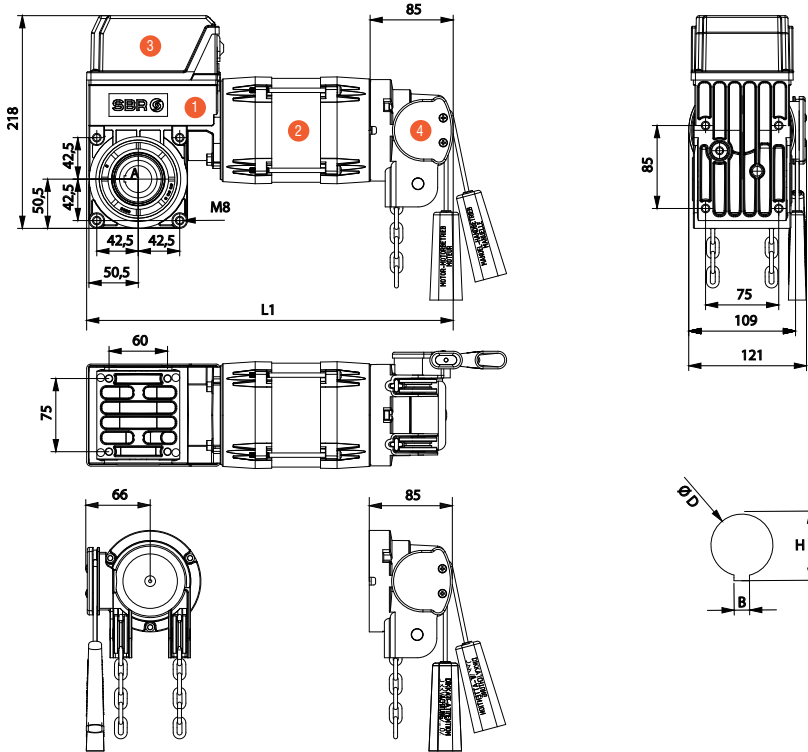

1	Gearbox
2	Motor
3	Limit Switch
4	Hand Crank C1

SD SERIES	L1
SD-050-0100-024	376
SD-050-0100-030	391
SD-050-0110-024	391
SD-050-0130-015	390
SD-050-0140-020	410
SD-050-0080-030-FI	391

ØD	H	B
D25.4	28,4	6,35
D31.75	34,7	6,35

## SD-50 WITH C2

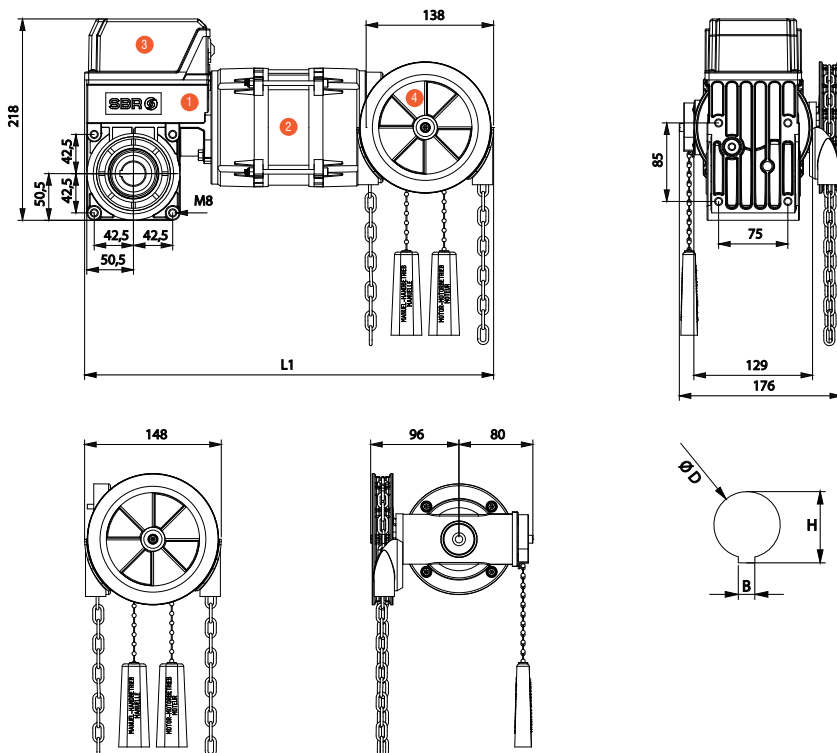

1	Gearbox
2	Motor
3	Limit Switch
4	Hand Crank C2

SD SERIES	L1
SD-050-0130-015	443
SD-050-0140-020	463
SD-050-0100-048-FI	453

ØD	H	B
D25.4	28,4	6,35
D31.75	34,7	6,35



## DIMENSIONS

### SD-50 WITH MK

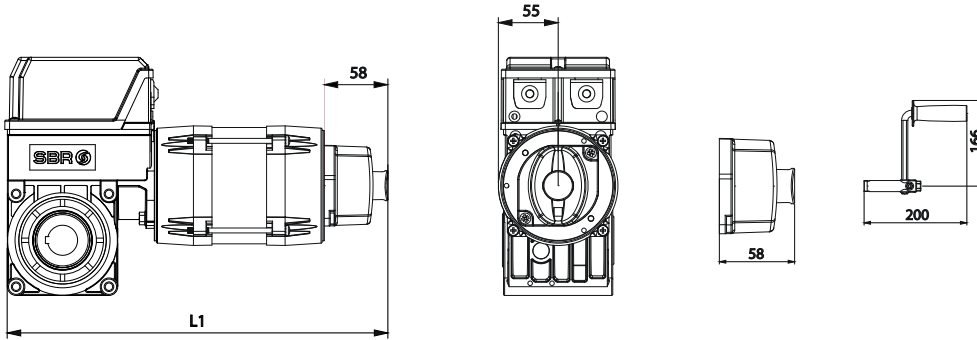

### SD-50 WITH RK

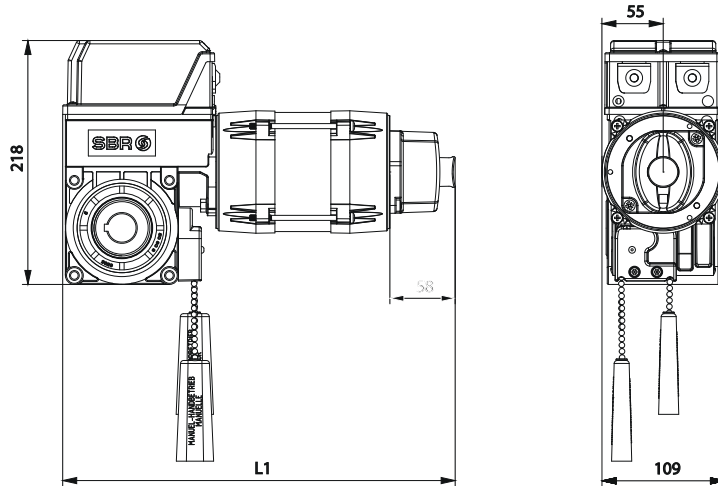

## ACCESSORIES

### 5610000500010-FLANGE BRACKET

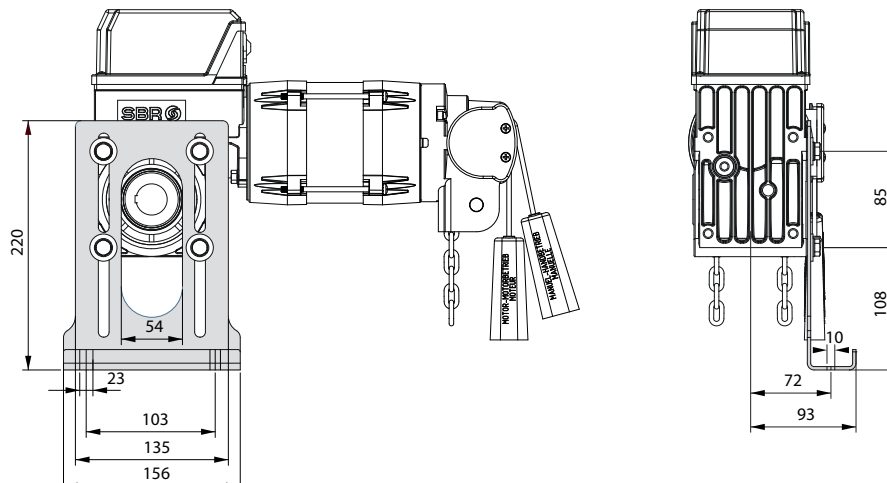

# DS SERIES

## NON BALANCED SECTIONAL DOORS DRIVES



# DS-NON BALANCED SECTIONAL DOOR DRIVES

		DS-50-140-20	DS-63-170-24	DS-63-200-19	DS-85-250-24	DS-85-350-24
--	--	--------------	--------------	--------------	--------------	--------------

## Mechanical Properties

Output Torque	Nm	140	170	200	250	350
Output Speed	rpm	20	24	19	24	24
Output Shaft <sup>1</sup>	mm	25,4 31,75	25,0 25,4 30,0 31,75	25,0 25,4 30,0 31,75	30,0 31,75 40,0	30,0 31,75 40,0
Max. Cycles Per Hour <sup>2</sup>	h	8	10	10	11	11
Limit Switch Range	rev	20	20	20	20	20
Max. Output Speed OPEN / CLOSE For Frequency Inverter Operation	rpm	34 / 20	42 / 24	32 / 24	42 / 30	42 / 30

## Electrical Properties

Motor Power	kW	0,55	0,75	0,75	0,75	1,10
Operating Voltage	V	3N~400	3N~400	3N~400	3N~400	3N~400
Operating Frequency	Hz	50/60	50/60	50/60	50/60	50/60
Operating Current <sup>4</sup>	A	3,9/2,3	4,4/2,6	4,6/2,7	4,6/2,7	5,6/3,3
Fuse Protection, On Site	A	10	10	10	10	10
Duty Types	ED	S3-%60	S3-%60	S3-%60	S3-%60	S3-%60
IP Protection Class	IP	54	54	54	54	54
Temperature Range <sup>5</sup>	°C	-20 40 (+60)	-20 +40 (+60)	-20 +40 (+60)	-20 +40 (+60)	-20 +40 (+60)
Working Noise Level	dB (A)	< 70	< 70	< 70	< 70	< 70

## Application

		kg	cm/sn	kg	cm/sn	kg	cm/sn	kg	cm/sn	kg	cm/sn
Sectional Doors Cable Drum [mm] <sup>A</sup>	FF NL 18	177	15,2	215	18,2	253	14,4	316	18,2	443	18,2
	F-160	161	16,7	195	20,1	229	15,9	287	20,1	401	20,1
	F-200	128	20,9	156	25,1	183	19,9	229	25,1	321	25,1

Roller Shutters Tube EN 10220 [mm] <sup>B</sup>	101,6	180	219	258	322	451
	108,0	172	208	245	307	429
	114,3	164	199	234	293	410
	133,0	145	175	206	258	361
	159,0	124	208	245	307	429
	177,8	--	137	161	201	281
	193,7	--	--	149	186	261
	219,1	--	--	--	167	234

Maximum suspended weight in kg

		DS-85-450-24	DS-85-600-15	DS-110-600-24	DS-110-800-24-HD	DS-110-1000-24-HD
--	--	--------------	--------------	---------------	------------------	-------------------

### Mechanical Properties

Property	Unit	DS-85-450-24	DS-85-600-15	DS-110-600-24	DS-110-800-24-HD	DS-110-1000-24-HD
Output Torque	Nm	450	600	600	800	1000
Output Speed	rpm	24	15	24	24	24
Output Shaft <sup>1</sup>	mm	30,0 31,75 40,0	40,0	55,0	55,0	55,0
Max. Cycles Per Hour <sup>2</sup>	h	11	9	7	8	7
Limit Switch Range	rev	20	20	20	20	20
Max. Output Speed OPEN / CLOSE For Frequency Inverter Operation	rpm	42 / 30	26 / 18	42 / 30	42 / 30	34 / 24

### Electrical Properties

Property	Unit	DS-85-450-24	DS-85-600-15	DS-110-600-24	DS-110-800-24-HD	DS-110-1000-24-HD
Motor Power	kW	1,5	1,1	1,5	2,2	3,0
Operating Voltage	V	3N~400	3N~400	3N~400	3N~400	3N~400
Operating Frequency	Hz	50/60	50/60	50/60	50/60	50/60
Operating Current <sup>3</sup>	A	7,7/4,5	7,7/4,5	7,7/4,5	12,3/7,2	15,3/9
Fuse Protection, On Site	A	10	10	10	10	10
Duty Types	ED	S3-%60	S3-%60	S3-%60	S3-%60	S3-%60
IP Protection Class	IP	54	54	54	54	54
Temperature Range <sup>4</sup>	°C	-20 +40 (+60)	-20 +40 (+60)	-20 +40 (+60)	-20 +40 (+60)	-20 +40 (+60)
Working Noise Level	dB (A)	< 70	< 70	< 70	< 70	< 70

### Application

Sectional Doors Cable Drum [mm] <sup>A</sup>	Type	DS-85-450-24		DS-85-600-15		DS-110-600-24		DS-110-800-24-HD		DS-110-1000-24-HD	
		kg	cm/sn	kg	cm/sn	kg	cm/sn	kg	cm/sn	kg	cm/sn
Sectional Doors Cable Drum [mm] <sup>A</sup>	F-160	516	20,1	688	12,6	688	20,1	--	--	--	--
	F-200	413	25,1	550	15,7	550	25,1	734	25,1	917	25,1

Roller Shutters Tube EN 10220 [mm] <sup>B</sup>	108,0	552	--	--	--	--
	114,3	527	703	--	--	--
	133,0	465	619	619	826	1032
	159,0	552	736	736	981	1226
	177,8	362	483	483	643	804
	193,7	336	447	447	597	746
	219,1	301	401	401	535	668
	244,5	--	363	363	484	605
	273,0	--	328	328	438	547
	298,5	--	--	303	403	504

Maximum suspended weight in kg

## DS-NON BALANCED SECTIONAL DOOR DRIVES

---

A safety brake antifall mechanism (parachute) which prevents free fall of the door just in case gear broken are built in gearbox.

1- Output shafts Ø25,0-Ø25,4-Ø30,0-Ø31,75-Ø40,0 mm etc. can be made upon request.

2- One cycle corresponds to two door movements (opening and closing). The specified values represent 10 revolutions of the drive shaft per movement and an even distribution is assumed. For other limit speed ranges or for heavily used doors, drag forces must be reduced. A motor with cooler and higher duty cycle should be selected. (Please ask)

3- Max. current in door drives can reach up to 4 times the rated operating current for limited times.

4- Allowable temperature -20°C.. +40°C (+60°C). When using the +40°C.. +60°C temperature range, half of the maximum movements per hour should be used.

↘ If frequency inverter drives are used, increasing the driving speed by 10% will cause a 5% decrease in drive torque. This should be considered when choosing a driver.

↘ In gearmotors powered at a frequency of 60Hz (and at the same voltage), multipliers are used for some performance figures: Output torque: 0.83 , and rotations in output: 1.2

### A- Driver Selection Table For Springless Doors

Using this table, the door drive can be determined easily and reliably.

The values in the table take into account safety reserve of 10%.

In some cases, the friction may be greater and these values should be taken into account when calculating.

For VL vertically raised doors, reduce weight by 20% more.

### B- Selection Of Suitable Drivers For Roller Shutters

To select the optimum drive solution, you will need the diameter of the winding shaft in mm and the suspended weight of the door in kg.

With the help of these parameters, the appropriate roller shutter drive can be determined easily and reliably using this table.

All indicated weights take into account a safety reserve of 20 % and a slat thickness of 25 mm.

In some cases, the friction may be greater and this condition should be taken into account when calculating.

For double-walled, thick or deep-section insulated lamellas, reduce the weight in the table by 20%. The highest load normally occurs after 1-2 rotations of the shutter.

Their extra friction and possible diameter changes due to over-winding, must be taken into account when calculating these values.

Special solutions can be offered upon request. Please contact us for requests in different speeds and powers.

# DIMENSIONS

## DS-50 WITH MK

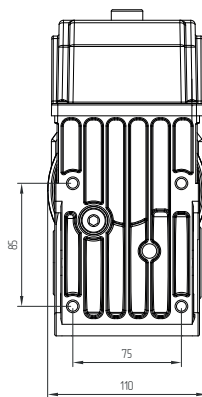
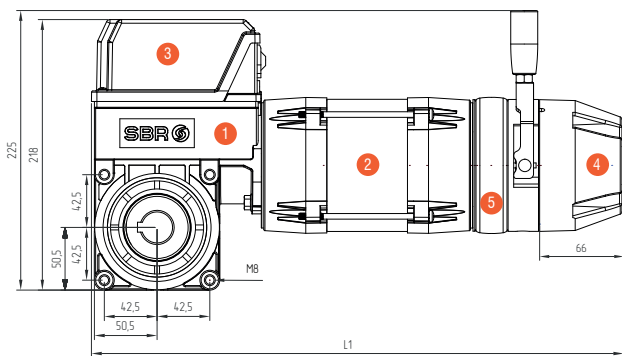

1	Gearbox
2	Motor
3	Limit Switch
4	Hand Crank MK
5	Brake

DS SERIES	L1
DS-50-140-20	410

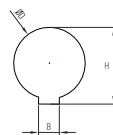
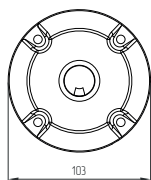
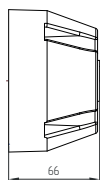

ØD	H	B
D25.4	28,4	6,35
D30.0	33,3	8,00
D31.75	34,7	6,35

## DS-50 WITH C2

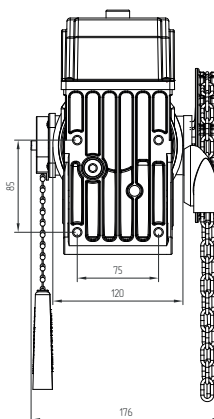
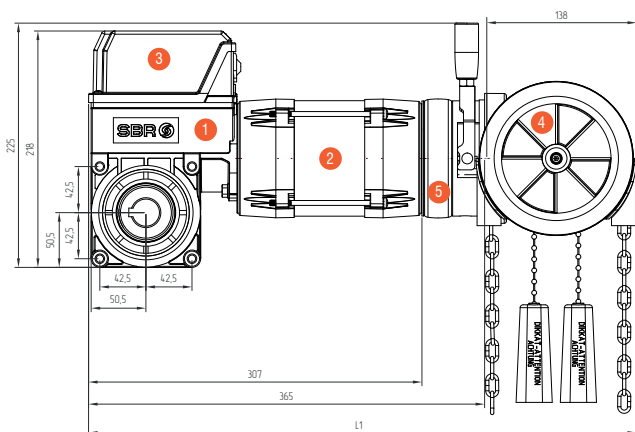

1	Gearbox
2	Motor
3	Limit Switch
4	Hand Crank C2
5	Brake

DS SERIES	L1
DS-50-140-20	463

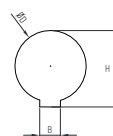
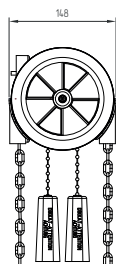
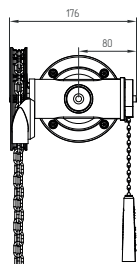

ØD	H	B
D25.4	28,4	6,35
D30.0	33,3	8,00
D31.75	34,7	6,35

# DIMENSIONS

## DS-63 WITH MK

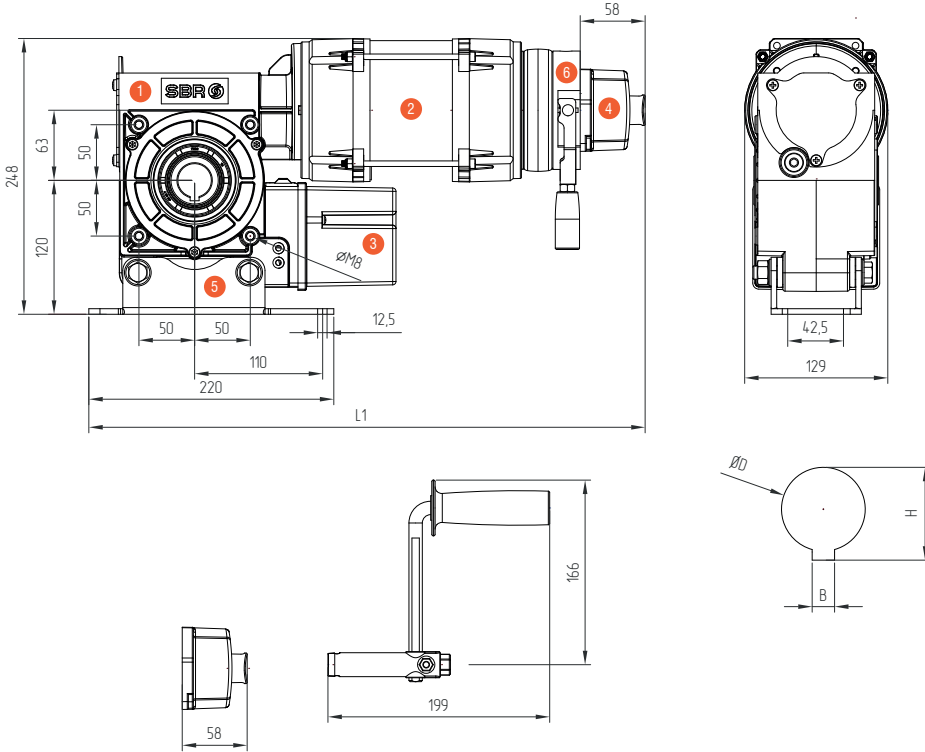

1	Gearbox
2	Motor
3	Limit Switch
4	Hand Crank MK
5	Floating Foot
6	Brake

DS SERIES	L1
DS-63-170-24	455
DS-63-200-19	455

ØD	H	B
D25.0	28,3	8,00
D25.4	28,4	6,35
D30.0	33,3	8,00
D31.75	34,7	6,35

## DS-63 WITH C2

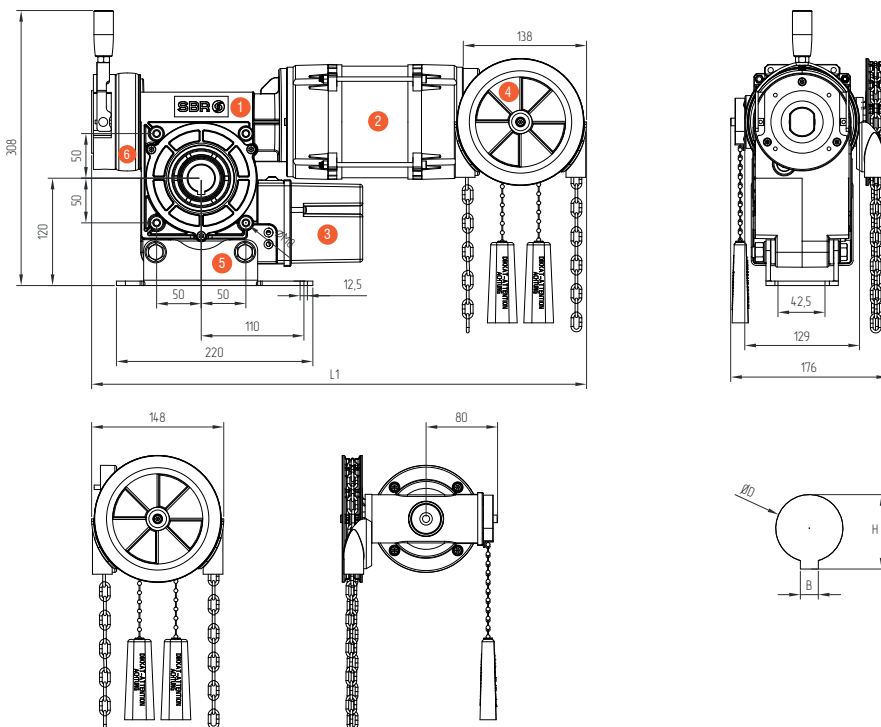

1	Gearbox
2	Motor
3	Limit Switch
4	Hand Crank C2
5	Floating Foot
6	Brake

DS SERIES	L1
DS-63-170-24	534
DS-63-200-19	534

ØD	H	B
D25.0	28,3	8,00
D25.4	28,4	6,35
D30.0	33,3	8,00
D31.75	34,7	6,35

# DIMENSIONS

## DS-85 WITH MK

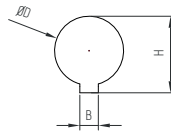
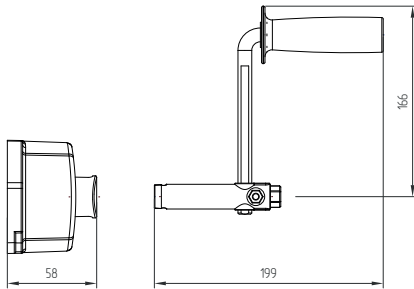
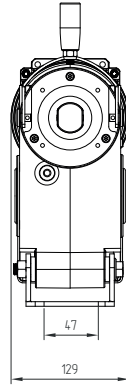
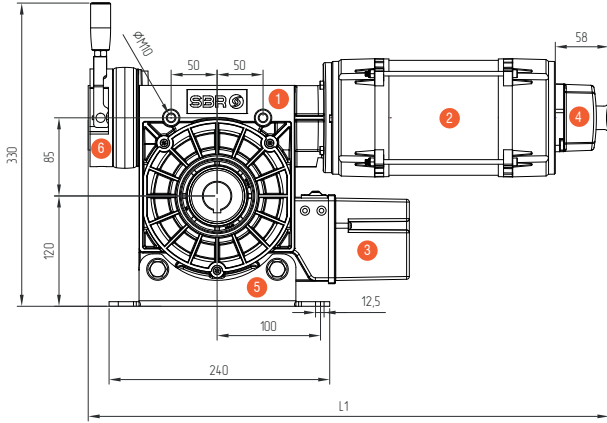

1	Gearbox
2	Motor
3	Limit Switch
4	Hand Crank MK
5	Floating Foot
6	Brake

DS SERIES	L1
DS-85-250-24	500
DS-85-350-24	520
DS-85-450-24	566
DS-85-550-15	520

ØD	H	B
D30.0	33,3	8,00
D31.75	34,7	6,35
D40.0	43,3	12,00

## DS-85 WITH C2

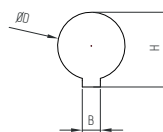
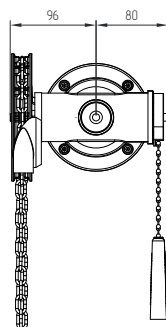
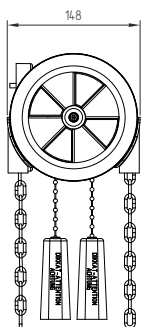
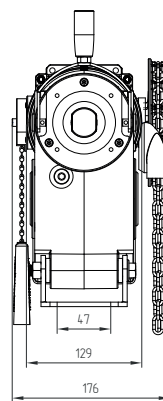
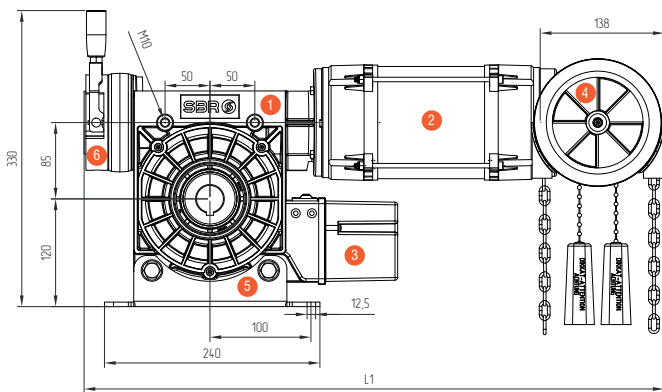

1	Gearbox
2	Motor
3	Limit Switch
4	Hand Crank C2
5	Floating Foot
6	Brake

DS SERIES	L1
DS-85-250-24	580
DS-85-350-24	600
DS-85-450-24	646
DS-85-550-15	600

ØD	H	B
D30.0	33,3	8,00
D31.75	34,7	6,35
D40.0	43,3	12,00



# DIMENSIONS

## DS-110 WITH MK

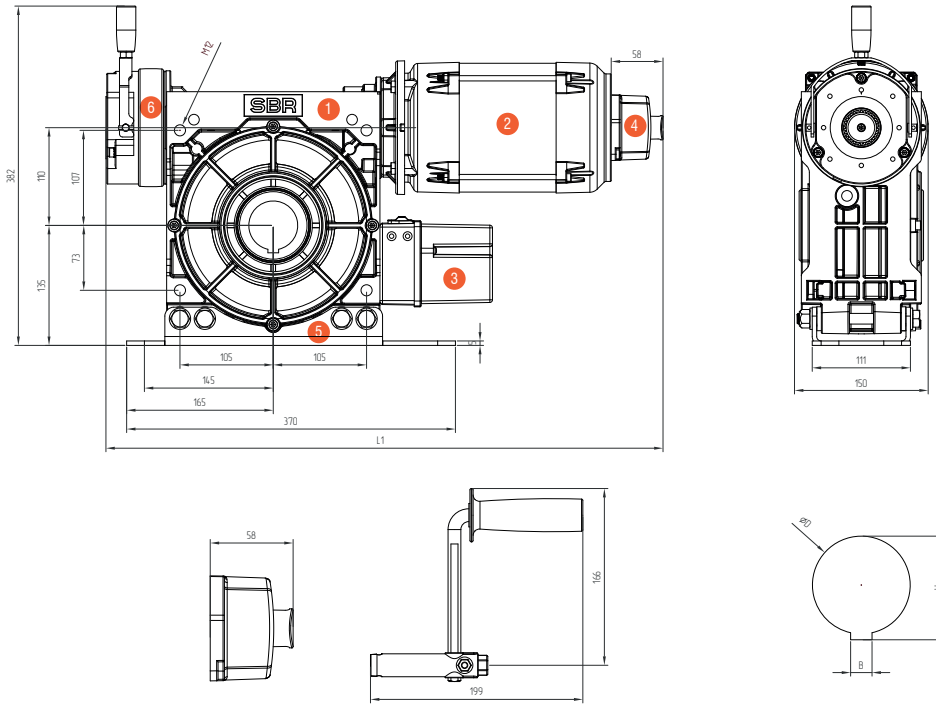

1	Gearbox
2	Motor
3	Limit Switch
4	Hand Crank MK
5	Floating Foot
6	Brake

DS SERIES	L1
DS-110-600-24	624
DS-110-750-24	627
DS-110-1000-24	627

ØD	H	B
D55.0	64,4	16,00

## DS-110 WITH C2

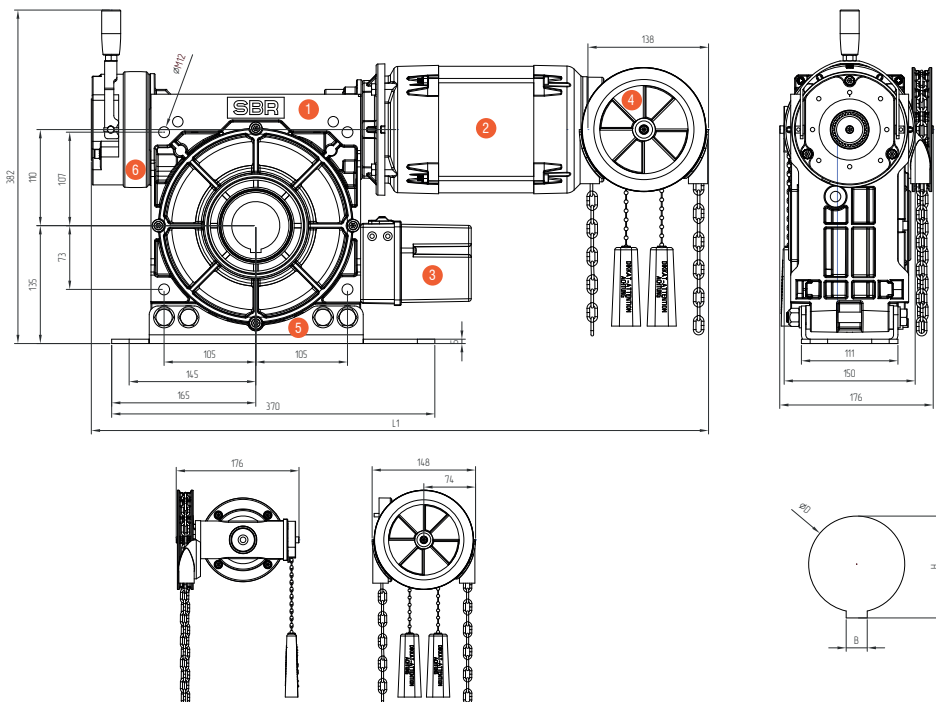

1	Gearbox
2	Motor
3	Limit Switch
4	Hand Crank C2
5	Floating Foot
6	Brake

DS SERIES	L1
DS-110-600-24	704
DS-110-750-24	707
DS-110-1000-24	707

ØD	H	B
D55.0	64,4	16,00

# RD SERIES

# ROLLER SHUTTER DOORS DRIVES



RD-50-130-15	RD-63-200-12	RD-85-250-10	RD-85-250-15	RD-85-400-15
--------------	--------------	--------------	--------------	--------------

### Mechanical Properties

Output Torque	Nm	130	200	250	250	400
Output Speed	rpm	15	12	10	15	15
Output Shaft <sup>1</sup>	mm	25,0 25,4 30	30,0	30,0 40,0	30,0 40,0	40,0
Max. Cycles Per Hour <sup>2</sup>	h	10	8	10	10	9
Limit Switch Range	rev	20	20	20	20	20
Max. output speed OPEN / CLOSE for frequency inverter operation	rpm	26 / 20	17 / 12	18 / 15	26 / 15	26 / 15

### Electrical Properties

Motor Power	kW	0,37	0,55	0,55	0,75	1,10
Operating Voltage	V	3N~400	3N~400	3N~400	3N~400	3N~400
Operating Frequency	Hz	50/60	50/60	50/60	50/60	50/60
Operating Current <sup>3</sup>	A	2,6/1,5	3,8/2,2	3,6/2,1	4,4/2,6	6,2/3,6
Fuse Protection, On Site	A	10	10	10	10	10
Duty Types	ED	S3-%60	S3-%60	S3-%60	S3-%60	S3-%60
IP Protection Class	IP	54	54	54	54	54
Temperature Range <sup>4</sup>	°C	-20 +40 (+60)	-20 +40 (+60)	-20 +40 (+60)	-20 +40 (+60)	-20 +40 (+60)
Working Noise Level	dB (A)	< 70	< 70	< 70	< 70	< 70

### Application

Roller shutters Tube EN 10220 [mm] <sup>A</sup>	101,6	167	258	322	322	515
	108,0	159	245	307	307	491
	114,3	152	234	293	293	468
	133,0	134	206	258	258	413
	159,0	115	177	222	222	355
	177,8	--	161	201	201	322
	193,7	--	--	186	186	298
	219,1	--	--	--	167	267

Maximum suspended weight in kg

	RD-85-400-10	RD-85-600-15	RD-110-800-15	RD-110-800-10	RD-110-1200-12	RD-110-1500-7	RD-110-1800-7
--	--------------	--------------	---------------	---------------	----------------	---------------	---------------

### Mechanical Properties

		RD-85-400-10	RD-85-600-15	RD-110-800-15	RD-110-800-10	RD-110-1200-12	RD-110-1500-7	RD-110-1800-7
Output Torque	Nm	400	600	800	800	1200	1500	1800
Output Speed	rpm	10	15	15	10	12	7	7
Output Shaft <sup>1</sup>	mm	40	40	55	55	55	55	55
Max. Cycles Per Hour <sup>2</sup>	h	9	9	6	7	6	5	5
Limit Switch Range	rev	20	20	20	20	20	20	20
Max. output speed OPEN / CLOSE for frequency inverter operation	rpm	18 / 15	26 / 15	26 / 26	18 / 18	20 / 20	10 / 10	10 / 10

### Electrical Properties

		RD-85-400-10	RD-85-600-15	RD-110-800-15	RD-110-800-10	RD-110-1200-12	RD-110-1500-7	RD-110-1800-7
Motor Power	kW	0,75	1,10	1,50	1,10	1,50	1,10	1,50
Operating Voltage	V	3N~400	3N~400	3N~400	3N~400	3N~400	3N~400	3N~400
Operating Frequency	Hz	50/60	50/60	50/60	50/60	50/60	50/60	50/60
Operating Current <sup>3</sup>	A	5,1/3,0	5,6/3,3	7,7/4,5	5,6/3,3	7,7/4,5	5,6/3,3	7,7/4,5
Fuse Protection, On Site	A	10	10	10	10	10	10	10
Duty Types	ED	S3-%60	S3-%60	S3-%60	S3-%60	S3-%60	S3-%60	S3-%60
IP Protection Class	IP	54	54	54	54	54	54	54
Temperature Range <sup>4</sup>	°C	-20 +40 (+60)	-20 +40 (+60)	-20 +40 (+60)	-20 +40 (+60)	-20 +40 (+60)	-20 +40 (+60)	-20 +40 (+60)
Working Noise Level	dB (A)	< 70	< 70	< 70	< 70	< 70	< 70	< 70

### Application

	108,0	114,3	133,0	159,0	177,8	193,7	219,1	244,5	273,0	298,5
Roller shutters Tube EN 10220 [mm] <sup>A</sup>	491	468	413	355	322	298	267	--	--	--
	--	703	619	532	483	447	401	363	328	--
	--	--	826	709	643	597	535	484	438	403
	--	--	826	709	643	597	535	484	438	403
	--	--	1239	1064	965	895	802	726	657	605
	--	--	--	1330	1206	1119	1002	908	821	756
	--	--	--	--	1448	1342	1203	1089	985	908

Maximum suspended weight in kg

## RD-ROLLER SHUTTER DOOR DRIVES

---

┌ A safety brake antifall mechanism (parachute) which prevents free fall of the door just in case gear broken are built in gearbox.

1- Output shafts Ø25,0-Ø25,4-Ø30,0-Ø31,75-Ø40,0 mm etc. can be made upon request.

2- One cycle corresponds to two door movements (opening and closing). The specified values represent 10 revolutions of the drive shaft per movement and an even distribution is assumed. For other limit speed ranges or for heavily used doors, drag forces must be reduced. A motor with cooler and higher duty cycle should be selected. (Please ask)

3- Max. current in door drives can reach up to 4 times the rated operating current for limited times.

4- Allowable temperature -20°C..+40°C (+60°C). When using the +40°C..+60°C temperature range, half of the maximum movements per hour should be used.

↳ If frequency inverter drives are used, increasing the driving speed by 10% will cause a 5% decrease in drive torque. This should be considered when choosing a driver.

↳ In gearmotors powered at a frequency of 60Hz (and at the same voltage), multipliers are used for some performance figures: Output torque: 0.83 , and rotations in output: 1.2

### ┌ A - Selection Of Suitable Drivers For Roller Shutters

To select the optimum drive solution, you will need the diameter of the winding shaft in mm and the suspended weight of the door in kg.

With the help of these parameters, the appropriate roller shutter drive can be determined easily and reliably using this table.

All indicated weights take into account a safety reserve of 20 % and a slat thickness of 25 mm.

In some cases, the friction may be greater and this condition should be taken into account when calculating.

For double-walled, thick or deep-section insulated lamellas, reduce the weight in the table by 20%. The highest load normally occurs after 1-2 rotations of the shutter.

Their extra friction and possible diameter changes due to over-winding, must be taken into account when calculating these values.

Special solutions can be offered upon request. Please contact us for requests in different speeds and powers.

# DIMENSIONS

## RD-50 WITH MK

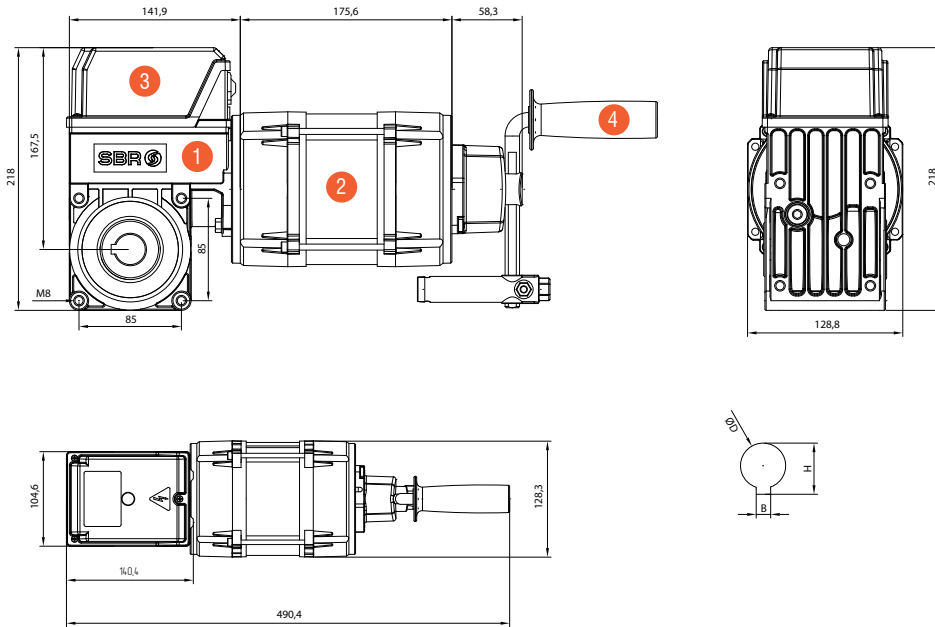

1	Gearbox
2	Motor
3	Limit Switch
4	Hand Crank MK

RD SERIES	L1
RD-50-130-15	363

ØD	H	B
D25.0	28,3	8,00
D25.4	28,4	6,35
D30.0	33,3	8,00

## RD-50 WITH C2

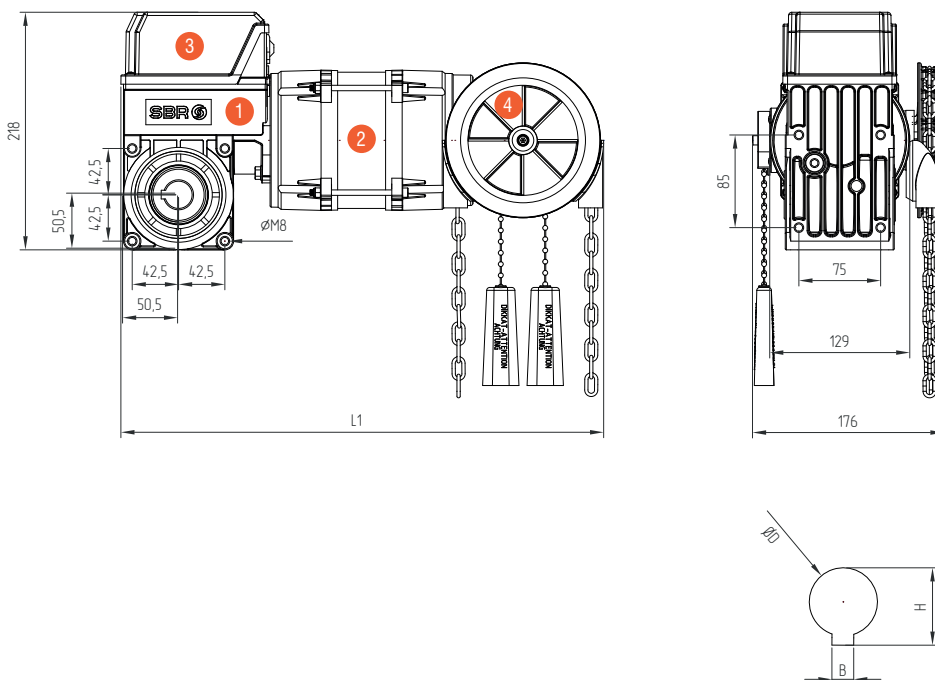

1	Gearbox
2	Motor
3	Limit Switch
4	Hand Crank C2

RD SERIES	L1
RD-50-130-15	443

ØD	H	B
D25.0	28,3	8,00
D25.4	28,4	6,35
D30.0	33,3	8,00

# DIMENSIONS

## RD-63 WITH MK

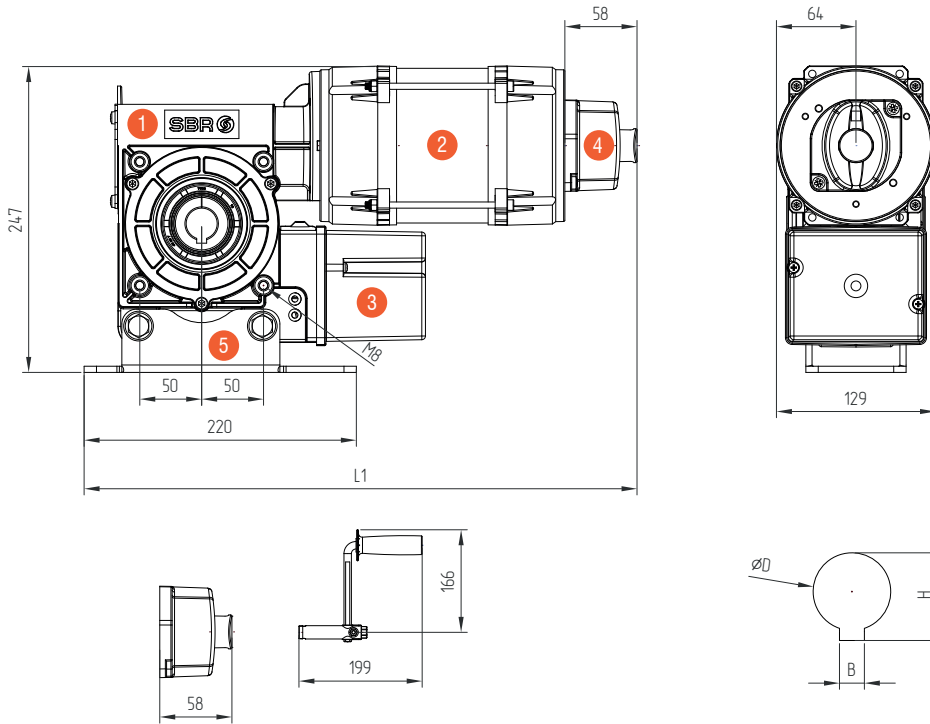

1	Gearbox
2	Motor
3	Limit Switch
4	Hand Crank MK
5	Floating Foot

RD SERIES	L1
RD-63-200-012	447

ØD	H	B
D30.0	33,3	8,00

## RD-63 WITH C2

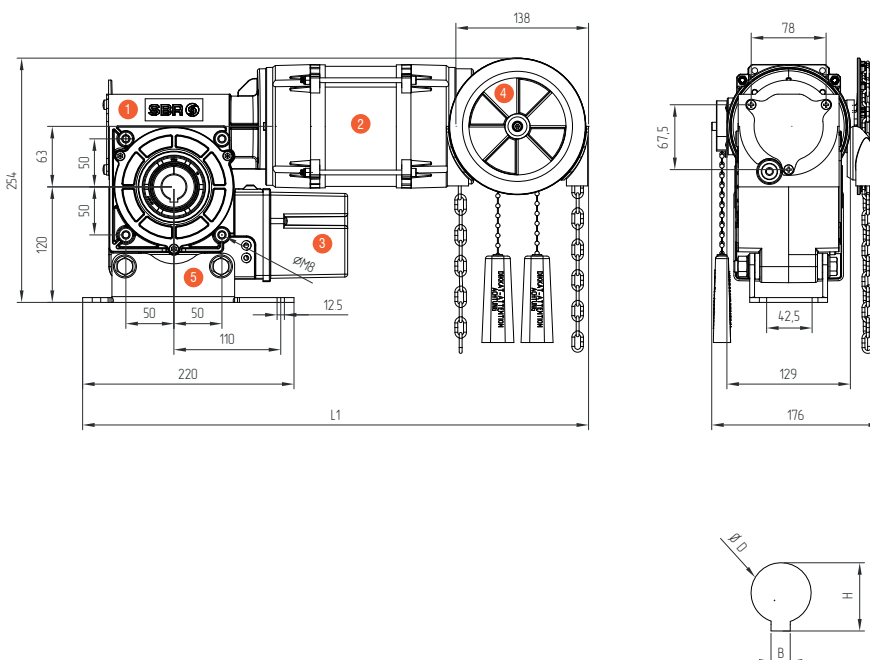

1	Gearbox
2	Motor
3	Limit Switch
4	Hand Crank C2
5	Floating Foot

RD SERIES	L1
RD-63-200-012	527

ØD	H	B
D30.0	33,3	8,00

# DIMENSIONS

## RD-85 WITH MK

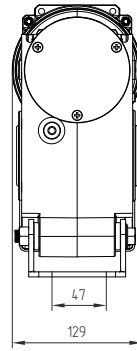
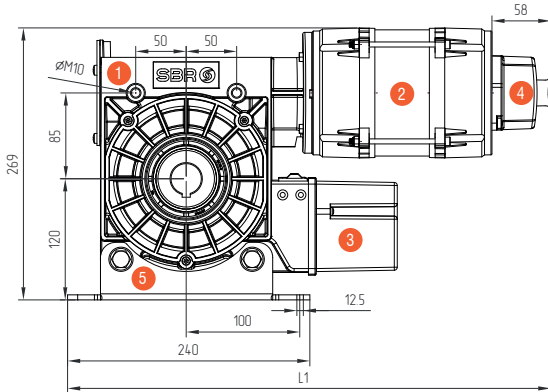

1	Gearbox
2	Motor
3	Limit Switch
4	Hand Crank MK
5	Floating Foot

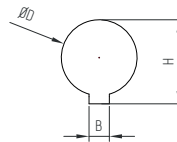
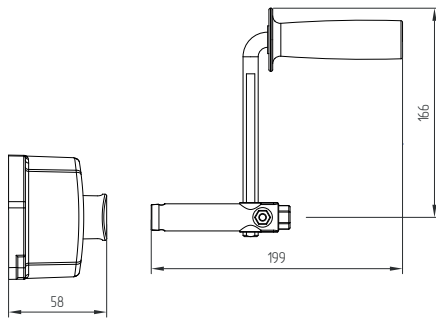

RD SERIES	L1
RD-85-250-010	499
RD-85-250-015	479
RD-85-400-015	499
RD-85-400-10	524

ØD	H	B
D30.0	33,3	8,00
D40.0	43,3	12,00

## RD-85 WITH C2

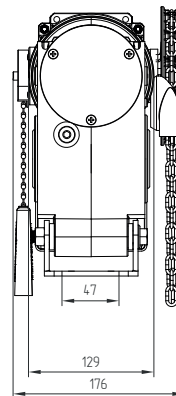
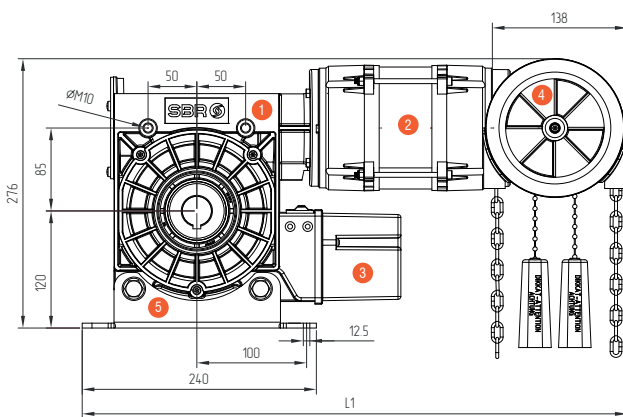

1	Gearbox
2	Motor
3	Limit Switch
4	Hand Crank C2
5	Floating Foot

RD SERIES	L1
RD-85-250-010	579
RD-85-250-015	559
RD-85-400-015	579
RD-85-400-10	604

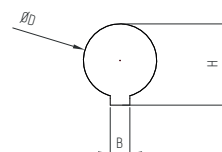

ØD	H	B
D30.0	33,3	8,00
D40.0	43,3	12,00



# DIMENSIONS

## RD-85-R2 WITH MK

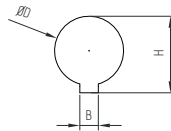
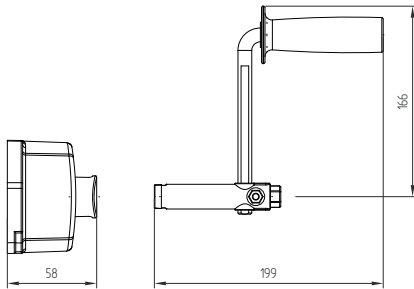
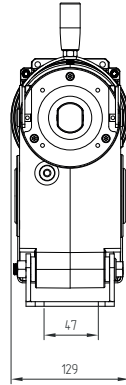
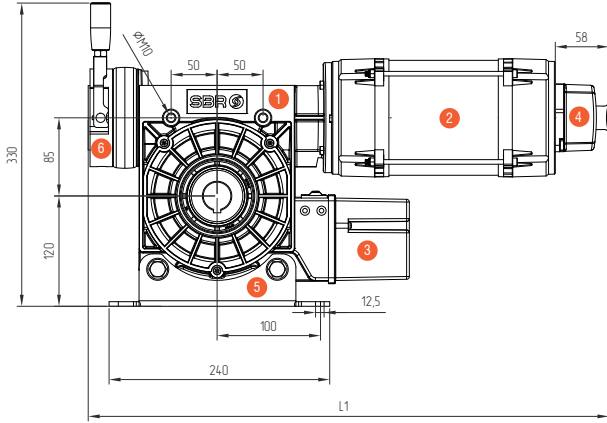

1	Gearbox
2	Motor
3	Limit Switch
4	Hand Crank MK
5	Floating Foot
6	Brake

RD SERIES	L1
RD-85-550-15	547

ØD	H	B
D30.0	33,3	8,00
D40.0	43,3	12,00

## RD-85-R2 WITH C2

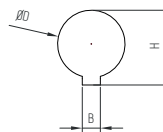
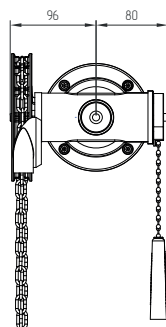
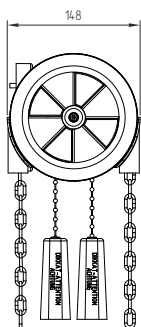
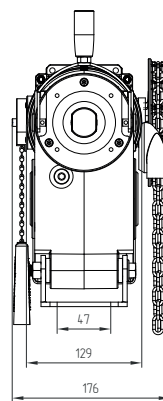
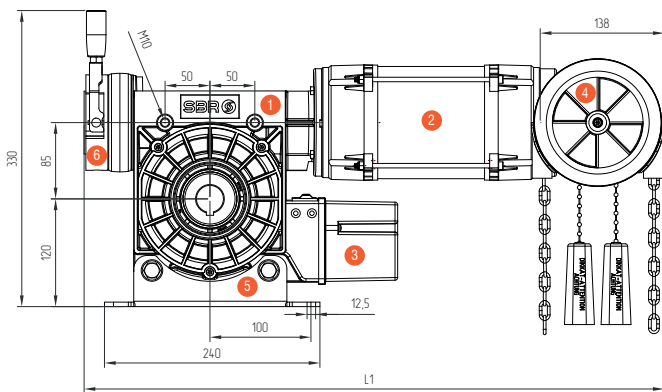

1	Gearbox
2	Motor
3	Limit Switch
4	Hand Crank C2
5	Floating Foot
6	Brake

RD SERIES	L1
RD-85-550-15	627

ØD	H	B
D30.0	33,3	8,00
D40.0	43,3	12,00

# DIMENSIONS

## RD-110-R2 WITH MK

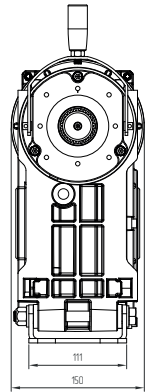
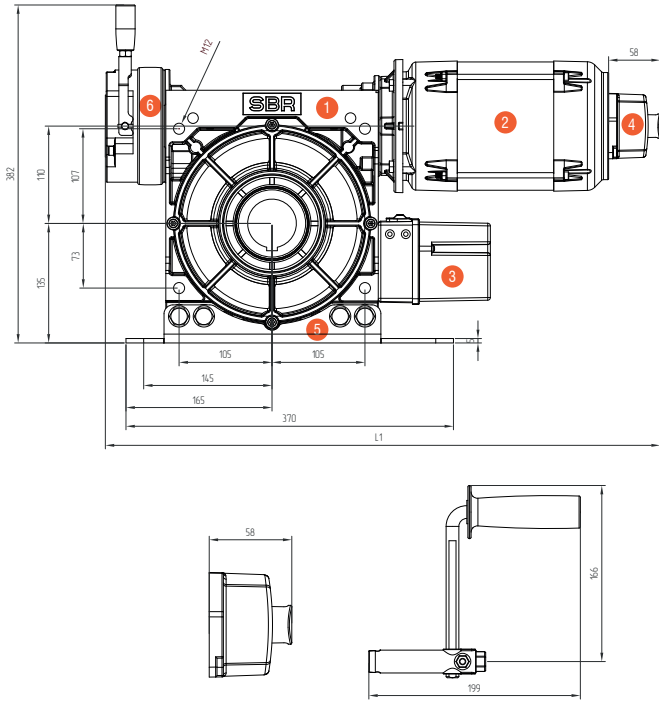

1	Gearbox
2	Motor
3	Limit Switch
4	Hand Crank MK
5	Floating Foot
6	Brake

RD SERIES	L1
RD-110-800-15	695
RD-110-800-10	685
RD-110-1000-10	695

ØD	H	B
D55.0	64,4	16,00

## RD-110-R2 WITH C2

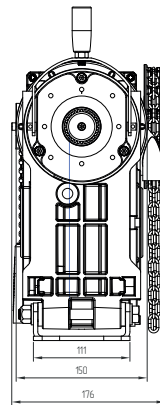
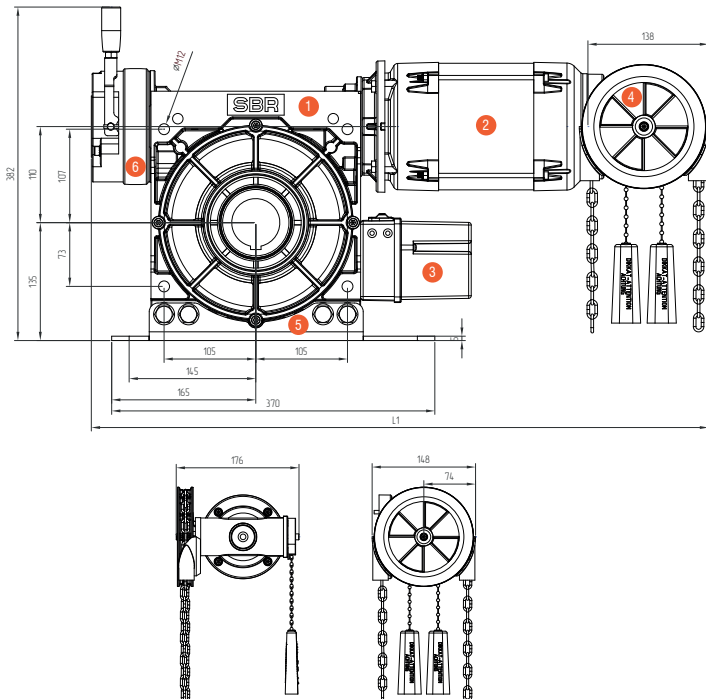

1	Gearbox
2	Motor
3	Limit Switch
4	Hand Crank C2
5	Floating Foot
6	Brake

RD SERIES	L1
RD-110-800-15	775
RD-110-800-10	765
RD-110-1000-10	775

ØD	H	B
D55.0	64,4	16,00

# PS SERIES

# HIGH SPEED DOORS DRIVES



PS-50-100-45	PS-50-45-95	PS-50-60-95	PS-50-40-140-FI	PS-63-160-45	PS-63-80-90	PS-63-60-135-FI
--------------	-------------	-------------	-----------------	--------------	-------------	-----------------

**Mechanical Properties**

Property	Unit	PS-50-100-45	PS-50-45-95	PS-50-60-95	PS-50-40-140-FI	PS-63-160-45	PS-63-80-90	PS-63-60-135-FI
Output Torque	Nm	100	45	60	40	160	80	60
Output Speed	rpm	45	95	95	140	45	90	135
Output Shaft <sup>1</sup>	mm	25,0 25,4 30,0 31,75	25,0 30,0	25,0 30,0	25,0 30,0	25,0 30,0	25,0 30,0	25,0 30,0
Max. Cycles Per Hour <sup>2</sup>	h	20	30	30	45	20	30	45
Limit Switch Range	rev	20	20	20	20	20	20	20
Max. output speed OPEN / CLOSE for frequency inverter operation	rpm	78 / 50	165 / 100	166 / 100	200 / 140	78 / 50	155 / 100	200 / 140

**Electrical Properties**

Property	Unit	PS-50-100-45	PS-50-45-95	PS-50-60-95	PS-50-40-140-FI	PS-63-160-45	PS-63-80-90	PS-63-60-135-FI
Motor Power	kW	0,75	0,55	0,75	0,75	1,10	1,10	1,10
Operating Voltage	V	3N~400	3N~400	3N~400	3N~400	3N~400	3N~400	3N~400
Operating Frequency	Hz	50/60	50/60	50/60	50/60	50/60	50/60	50/60
Operating Current <sup>3</sup>	A	3,6/1,9	2,8/1,6	3,6/1,9	3,6/1,9	5,0/2,9	5,2/3,0	5,2/3,0
Fuse Protection, On Site	A	10	10	10	10	10	10	10
Duty Types	ED	S3-%60	S3-%60	S3-%60	S3-%60	S3-%60	S3-%60	S3-%60
IP Protection Class	IP	54	54	54	54	54	54	54
Temperature Range <sup>4</sup>	°C	-20 +40 (+60)	-20 +40 (+60)	-20 +40 (+60)	-20 +40 (+60)	-20 +40 (+60)	-20 +40 (+60)	-20 +40 (+60)
Working Noise Level	dB (A)	< 70	< 70	< 70	< 70	< 70	< 70	< 70

**Application**

	PIPE (Ø)	50 Hz - (87Hz)	50 Hz - (87Hz)	50 Hz - (87Hz)	50 Hz - (87Hz)	50 Hz - (87Hz)	50 Hz - (87Hz)	50 Hz - (87Hz)
Weights That Motors Can Lift According To Winding Diameter For PS Roll Door (Kg)	101,6	129 - (90)	58 - (41)	77 - (54)	52 - (36)	206 - (144)	103 - (72)	77 - (54)
	108,0	123 - (86)	55 - (39)	74 - (52)	49 - (34)	195 - (137)	98 - (69)	74 - (52)
	114,3	117 - (82)	53 - (37)	70 - (49)	47 - (33)	188 - (131)	94 - (66)	70 - (49)
	133,0	103 - (72)	46 - (33)	62 - (43)	41 - (29)	165 - (116)	83 - (58)	62 - (43)
	159,0	99 - (69)	44 - (31)	59 - (42)	40 - (28)	158 - (111)	79 - (55)	59 - (42)
	177,8	89 - (62)	40 - (28)	53 - (37)	35 - (25)	142 - (99)	71 - (50)	53 - (37)
	193,7	75 - (52)	34 - (23)	45 - (31)	30 - (21)	119 - (84)	60 - (42)	45 - (31)
	219,1	67 - (47)	30 - (21)	40 - (28)	55 - (39)	25 - (17)	37 - (26)	55 - (39)

Weights That Motors Can Lift According To Winding Diameter For PS Folding Door (Kg)	101,6	152 - (106)	68 - (48)	91 - (64)	61 - (42)	243 - (170)	121 - (85)	91 - (64)
	108,0	143 - (100)	64 - (45)	86 - (60)	57 - (40)	229 - (160)	114 - (80)	86 - (60)
	114,0	136 - (95)	61 - (43)	82 - (57)	54 - (38)	217 - (152)	109 - (76)	82 - (57)
	133,0	117 - (82)	53 - (37)	70 - (49)	47 - (33)	188 - (131)	94 - (66)	70 - (49)
	140,0	112 - (78)	50 - (35)	67 - (47)	45 - (31)	179 - (125)	89 - (63)	67 - (47)
	159,0	99 - (69)	44 - (31)	59 - (42)	40 - (28)	158 - (111)	79 - (55)	59 - (42)
	193,7	82 - (57)	37 - (26)	49 - (34)	33 - (23)	131 - (91)	65 - (46)	49 - (34)
	219,1	72 - (51)	33 - (23)	43 - (30)	29 - (20)	116 - (81)	58 - (41)	43 - (30)

Maximum suspended weight in kg

	PS-85-300-35	PS-85-400-35	PS-85-140-90	PS-85-200-90	PS-85-250-90
--	--------------	--------------	--------------	--------------	--------------

**Mechanical Properties**

		PS-85-300-35	PS-85-400-35	PS-85-140-90	PS-85-200-90	PS-85-250-90
Output Torque	Nm	300	400	140	200	250
Output Speed	rpm	35	35	90	90	90
Output Shaft <sup>1</sup>	mm	30,0 40,0	30,0 40,0	30,0 40,0	30,0 40,0	30,0 40,0
Max. Cycles Per Hour <sup>2</sup>	h	30	20	45	30	20
Limit Switch Range	rev	20	20	20	20	20
Max. output speed OPEN / CLOSE for frequency inverter operation	rpm	60 / 40	60 / 40	155 / 100	155 / 100	155 / 100

**Electrical Properties**

		PS-85-300-35	PS-85-400-35	PS-85-140-90	PS-85-200-90	PS-85-250-90
Motor Power	kW	1,10	1,50	1,50	2,20	3,00
Operating Voltage	V	3N~400	3N~400	3N~400	3N~400	3N~400
Operating Frequency	Hz	50/60	50/60	50/60	50/60	50/60
Operating Current <sup>3</sup>	A	5,2/3,0	8,8/5,1	8,8/5,1	11,0/6,5	14,5/8,4
Fuse Protection, On Site	A	10	10	10	10	16
Duty Types	ED	S3-%60	S3-%60	S3-%60	S3-%60	S3-%60
IP Protection Class	IP	54	54	54	54	54
Temperature Range <sup>4</sup>	°C	-20 +40 (+60)	-20 +40 (+60)	-20 +40 (+60)	-20 +40 (+60)	-20 +40 (+60)
Working Noise Level	dB (A)	< 70	< 70	< 70	< 70	< 70

**Application**

	PIPE (Ø)	50 Hz - (87Hz)	50 Hz - (87Hz)	50 Hz - (87Hz)	50 Hz - (87Hz)	50 Hz - (87Hz)
Weights That Motors Can Lift According To Winding Diameter For PS Roll Door (Kg)	101,6	386 - (271)	515 - (361)	180 - (126)	258 - (180)	322 - (225)
	114,0	352 - (246)	469 - (329)	164 - (115)	235 - (164)	293 - (205)
	133,0	310 - (217)	413 - (289)	145 - (101)	206 - (145)	258 - (181)
	159,0	266 - (186)	355 - (248)	124 - (87)	177 - (124)	222 - (155)
	193,7	224 - (157)	298 - (209)	104 - (73)	149 - (104)	186 - (131)
	219,1	200 - (140)	267 - (187)	94 - (65)	134 - (94)	167 - (117)

Weights That Motors Can Lift According To Winding Diameter For PS Folding Door (Kg)	101,6	455 - (318)	606 - (424)	212 - (149)	303 - (212)	379 - (265)
	108,0	429 - (300)	572 - (401)	200 - (140)	286 - (200)	358 - (250)
	114,0	408 - (285)	544 - (381)	190 - (133)	272 - (190)	340 - (238)
	133,0	352 - (246)	469 - (329)	164 - (115)	235 - (164)	293 - (205)
	140,0	335 - (235)	447 - (313)	156 - (109)	223 - (156)	279 - (195)
	159,0	297 - (208)	395 - (277)	138 - (97)	198 - (138)	247 - (173)
	193,7	245 - (172)	327 - (229)	114 - (80)	163 - (114)	204 - (143)
	219,1	217 - (152)	290 - (203)	101 - (71)	145 - (101)	181 - (127)

Maximum suspended weight in kg

	PS-85-100-140-FI	PS-85-130-140-FI	PS-85-150-140-FI	PS-85-70-180-FI	PS-85-100-180-FI	PS-85-140-180-FI
--	------------------	------------------	------------------	-----------------	------------------	------------------

**Mechanical Properties**

		PS-85-100-140-FI	PS-85-130-140-FI	PS-85-150-140-FI	PS-85-70-180-FI	PS-85-100-180-FI	PS-85-140-180-FI
Output Torque	Nm	100	130	150	70	100	140
Output Speed	rpm	140	140	140	180	180	180
Output Shaft <sup>1</sup>	mm	30,0 40,0	30,0 40,0	30,0 40,0	30,0 40,0	30,0 40,0	30,0 40,0
Max. Cycles Per Hour <sup>2</sup>	h	45	30	20	50	30	30
Limit Switch Range	rev	20	20	20	20	20	20
Max. output speed OPEN / CLOSE for frequency inverter operation	rpm	240 / 140	240 / 140	240 / 140	240 / 140	240 / 140	240 / 140

**Electrical Properties**

		PS-85-100-140-FI	PS-85-130-140-FI	PS-85-150-140-FI	PS-85-70-180-FI	PS-85-100-180-FI	PS-85-140-180-FI
Motor Power	kW	1,50	2,20	3,00	1,50	2,20	3,00
Operating Voltage	V	3N~400	3N~400	3N~400	3N~400	3N~400	3N~400
Operating Frequency	Hz	50/60	50/60	50/60	50/60	50/60	50/60
Operating Current <sup>3</sup>	A	7,5/4,3	12,3/7,2	15,3/9	7,5/4,3	12,3/7,2	15,3/9,0
Fuse Protection, On Site	A	10	16	16	10	16	16
Duty Types	ED	S3-%60	S3-%60	S3-%60	S3-%60	S3-%60	S3-%60
IP Protection Class	IP	54	54	54	54	54	54
Temperature Range <sup>4</sup>	°C	-20 +40 (+60)	-20 +40 (+60)	-20 +40 (+60)	-20 +40 (+60)	-20 +40 (+60)	-20 +40 (+60)
Working Noise Level	dB (A)	< 70	< 70	< 70	< 70	< 70	< 70

**Application**

	PIPE (Ø)	50 Hz - (87Hz)	50 Hz - (87Hz)	50 Hz - (87Hz)	50 Hz - (87Hz)	50 Hz - (87Hz)	50 Hz - (87Hz)
Weights That Motors Can Lift According To Winding Diameter For PS Roll Door (Kg)	101,6	129 - (90)	167 - (117)	193 - (135)	90 - (63)	129 - (90)	180 - (126)
	114,0	117 - (82)	153 - (107)	176 - (123)	82 - (57)	117 - (82)	164 - (115)
	133,0	103 - (72)	134 - (94)	155 - (108)	72 - (51)	103 - (72)	145 - (101)
	159,0	89 - (62)	115 - (81)	133 - (93)	62 - (43)	89 - (62)	124 - (87)
	193,7	75 - (52)	97 - (68)	112 - (78)	52 - (37)	75 - (52)	104 - (73)
	219,1	67 - (47)	87 - (61)	100 - (70)	47 - (33)	67 - (47)	94 - (65)

Weights That Motors Can Lift According To Winding Diameter For PS Folding Door (Kg)	101,6	152 - (106)	197 - (138)	227 - (159)	106 - (74)	152 - (106)	212 - (149)
	108,0	143 - (100)	186 - (130)	215 - (150)	100 - (70)	143 - (100)	200 - (140)
	114,0	136 - (95)	177 - (124)	204 - (143)	95 - (67)	136 - (95)	190 - (133)
	133,0	117 - (82)	153 - (107)	176 - (123)	82 - (57)	117 - (82)	164 - (115)
	140,0	112 - (78)	145 - (102)	168 - (117)	78 - (55)	112 - (78)	156 - (109)
	159,0	99 - (69)	129 - (90)	148 - (104)	69 - (48)	99 - (69)	138 - (97)
	193,7	82 - (57)	106 - (74)	123 - (86)	57 - (40)	82 - (57)	114 - (80)
	219,1	72 - (51)	94 - (66)	109 - (76)	51 - (36)	72 - (51)	101 - (71)

Maximum suspended weight in kg

## PS-HIGH SPEED DOOR DRIVES

---

┌ A safety brake antifall mechanism (parachute) which prevents free fall of the door just in case gear broken are built in gearbox.

1- Output shafts Ø25,0-Ø25,4-Ø30,0-Ø31,75-Ø40,0 mm etc. can be made upon request.

2- One cycle corresponds to two door movements (opening and closing). The specified values represent 10 revolutions of the drive shaft per movement and an even distribution is assumed. Other limit speed ranges, ambient temperature and extra friction affect the value.

3- The current in door drives can reach up to 4 times the rated operating current for limited times.

4- Allowable temperature -20°C..+40°C (+60°C). When using the +40°C..+60°C temperature range, half of the maximum movements per hour should be used.

↳ If frequency inverter drives are used, increasing the driving speed by 10% will cause a 5% decrease in drive torque. This should be considered when choosing a driver.

↳ In gearmotors powered at a frequency of 60Hz (and at the same voltage), multipliers are used for some performance figures: Output torque: 0.83 , and rotations in output: 1.2

↳ For drives with external electromagnetic brakes, Brake inspection should always be performed by qualified service engineers.

### ┌ Selection Of Suitable Drive For Fast Pvc Door

To choose the optimal drive solution, you will need the diameter of the winding spindle in mm and the hanging weight of the door in kg.

With the help of these parameters, the appropriate door drive can be determined easily and reliably using this table.

Values in the table; It takes into account a curtain thickness of 25 mm for spiral PVC doors and 6 mm for folding PVC doors and a 20% safety reserve.

Extra friction and possible diameter changes due to over-winding in the first place should be taken into account when calculating these values.

The PS -FI series is for operation with a frequency converter. PS FI series; is the maximum weights at a frequency of 87 Hz, in the second row in the weight table.

Special solutions can be offered upon request. Please contact us for requests in different speeds and powers.

# DIMENSIONS

## PS-50 WITH MK

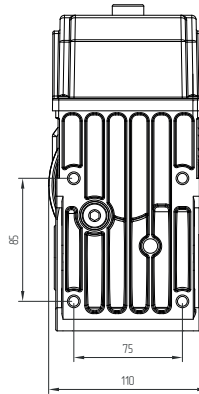
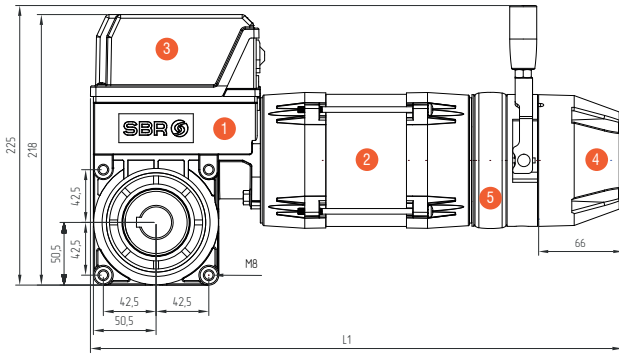

1	Gearbox
2	Motor
3	Limit Switch
4	Hand Crank MK

PS SERIES	L1
PS-50-100-45	410
PS-50-45-95	405
PS-50-60-95	410
PS-50-40-140-FI	410

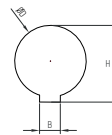
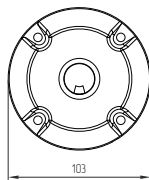
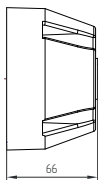

ØD	H	B
D25.0	28,3	8,00
D25.4	28,4	6,35
D30.0	33,3	8,00
D31.75	34,7	6,35

## PS-50 WITH C2

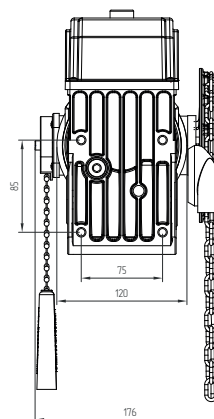
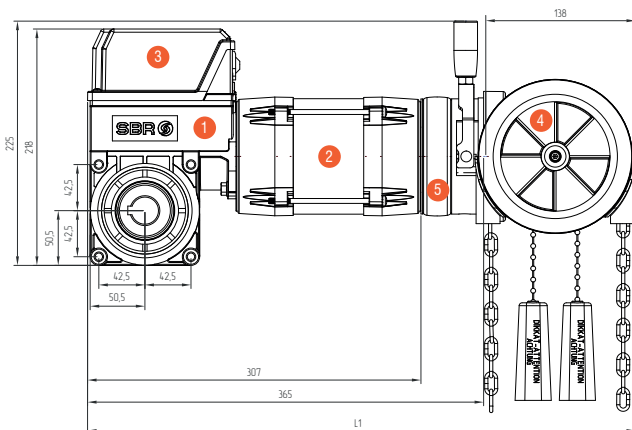

1	Gearbox
2	Motor
3	Limit Switch
4	Hand Crank C2

PS SERIES	L1
PS-50-100-45	490
PS-50-45-95	495
PS-50-60-95	490
PS-50-40-140-FI	490

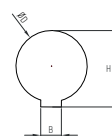
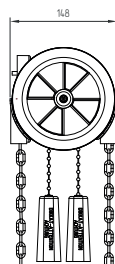
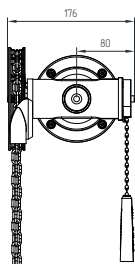

ØD	H	B
D25.0	28,3	8,00
D25.4	28,4	6,35
D30.0	33,3	8,00
D31.75	34,7	6,35



# DIMENSIONS

## PS-63 WITH MK

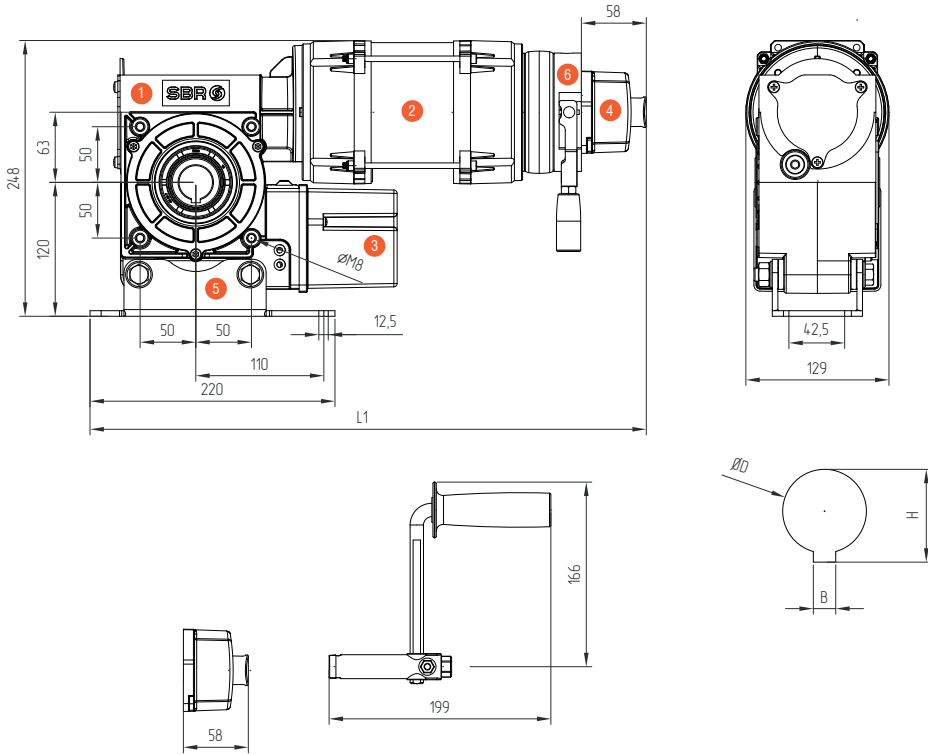

1	Gearbox
2	Motor
3	Limit Switch
4	Hand Crank MK
5	Floating Foot
6	Brake

PS SERIES	L1
PS-63-160-45	455
PS-63-80-90	455
PS-63-60-135-FI	455

ØD	H	B
D25.0	28,3	8,00
D30.0	33,3	8,00

## PS-63 WITH C2

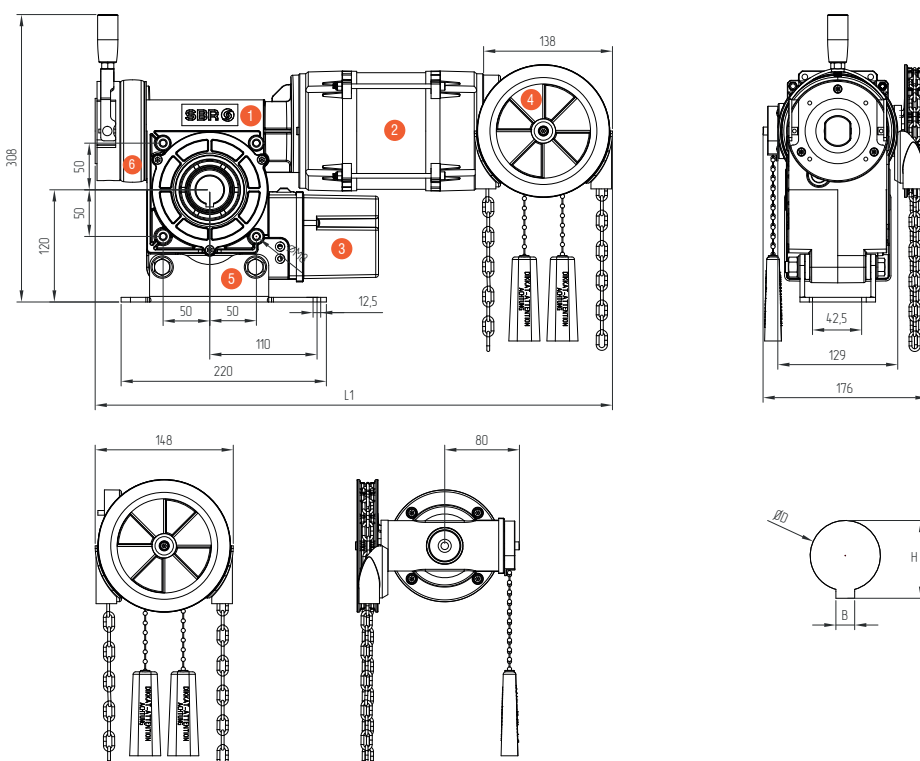

1	Gearbox
2	Motor
3	Limit Switch
4	Hand Crank C2
5	Floating Foot
6	Brake

PS SERIES	L1
PS-63-160-45	535
PS-63-80-90	535
PS-63-60-135-FI	535

ØD	H	B
D25.0	28,3	8,00
D30.0	33,3	8,00

# DIMENSIONS

## PS-85 WITH MK

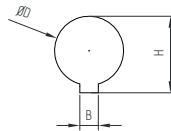
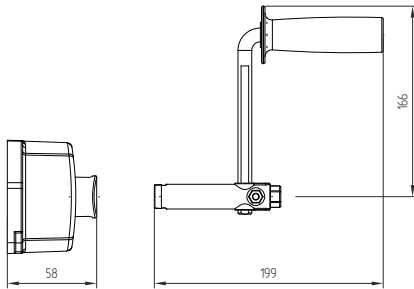
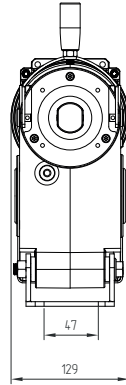
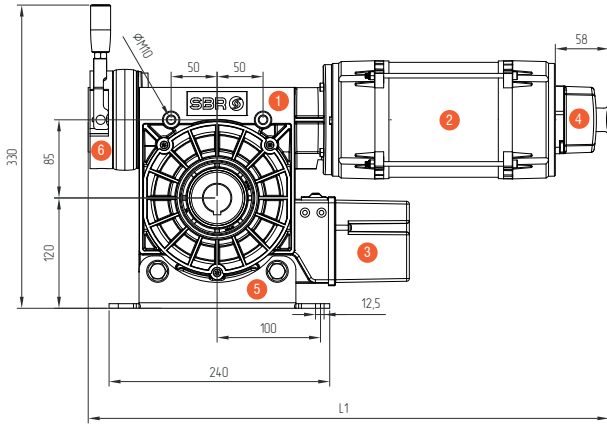

1	Gearbox
2	Motor
3	Limit Switch
4	Hand Crank MK
5	Floating Foot
6	Brake

PS SERIES	L1
PS-85-300-35	520
PS-85-140-90	566
PS-85-200-90	570
PS-85-250-90	570
PS-85-100-140-FI	571
PS-85-130-140-FI	575
PS-85-150-140-FI	575

ØD	H	B
D30.0	33,3	8,00
D40.0	43,3	12,00

## PS-85 WITH C2

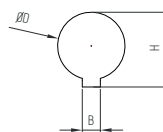
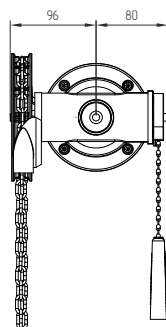
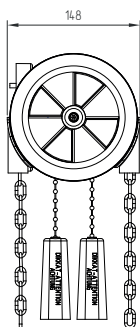
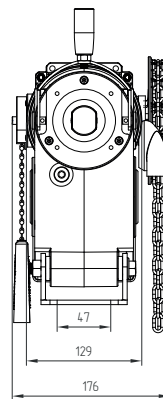
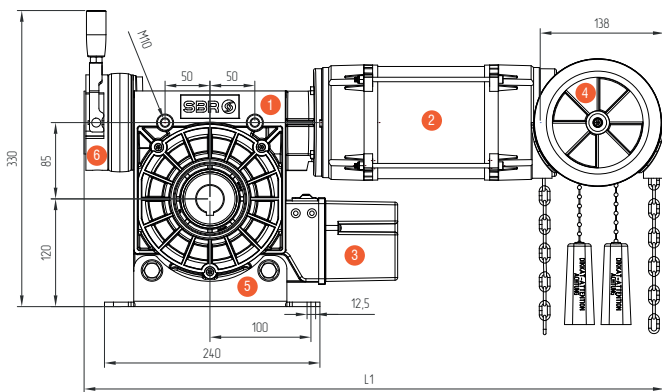

1	Gearbox
2	Motor
3	Limit Switch
4	Hand Crank C2
5	Floating Foot
6	Brake

PS SERIES	L1
PS-85-300-35	600
PS-85-140-90	646
PS-85-200-90	650
PS-85-250-90	650
PS-85-100-140-FI	651
PS-85-130-140-FI	655
PS-85-150-140-FI	655

ØD	H	B
D30.0	33,3	8,00
D40.0	43,3	12,00

**KD SERIES**

**CHAIN TRANSMISSION  
DOORS DRIVES**



KD-50-100-24	KD-63-170-24	KD-85-250-24	KD-85-350-24	KD-85-450-24	KD-110-600-24	KD-110-800-24-HD	KD-110-1000-24-HD
--------------	--------------	--------------	--------------	--------------	---------------	------------------	-------------------

## Mechanical Properties

	Nm	100	170	250	350	450	600	800	1000
Output Torque	Nm	100	170	250	350	450	600	800	1000
Output Speed	rpm	24	24	24	24	24	24	24	24
Output Shaft <sup>1</sup>	mm	25	30	40	40	40	55	55	55
Max. Cycles Per Hour <sup>2</sup>	h	8	10	11	11	11	7	7	7
Limit Switch Range	rev	20	20	20	20	20	20	20	20

## Electrical Properties

	kW	0,37	0,75	0,75	1,10	1,50	1,50	2,20	3,00
Motor Power	kW	0,37	0,75	0,75	1,10	1,50	1,50	2,20	3,00
Operating Voltage	V	3N~400	3N~400	3N~400	3N~400	3N~400	3N~400	3N~400	3N~400
Operating Frequency	Hz	50/60	50/60	50/60	50/60	50/60	50/60	50/60	50/60
Operating Current <sup>3</sup>	A	2,7/1,6	4,4/2,6	4,6/2,7	5,6/3,3	7,7/4,5	7,7/4,5	12,3/7,2	15,3/9,0
Fuse Protection, On Site	A	10	10	10	10	10	10	15	15
Duty Types	ED	S3-%60	S3-%60	S3-%60	S3-%60	S3-%60	S3-%60	S3-%60	S3-%60
IP Protection Class	IP	54	54	54	54	54	54	54	54
Temperature Range <sup>4</sup>	°C	-20 +40 (+60)	-20 +40 (+60)	-20 +40 (+60)	-20 +40 (+60)	-20 +40 (+60)	-20 +40 (+60)	-20 +40 (+60)	-20 +40 (+60)
Working Noise Level	dB (A)	< 70	< 70	< 70	< 70	< 70	< 70	< 70	< 70

<sup>1</sup> - Output shafts Ø25,0-Ø25,4-Ø30,0-Ø31,75-Ø40,0 mm etc. can be made upon request.

<sup>2</sup> - One cycle corresponds to two door movements (opening and closing). The specified values represent 10 revolutions of the drive shaft per movement and an even distribution is assumed. Other limit speed ranges, ambient temperature and extra friction affect the value.

<sup>3</sup> - The current in door drives can reach up to 4 times the rated operating current for limited times.

<sup>4</sup> - Allowable temperature -20°C.. +40°C (+60°C). When using the +40°C.. +60°C temperature range, half of the maximum movements per hour should be used.

↘ If frequency inverter drives are used, increasing the driving speed by 10% will cause a 5% decrease in drive torque. This should be considered when choosing a driver.

↘ In gearmotors powered at a frequency of 60Hz (and at the same voltage), multipliers are used for some performance figures: Output torque: 0.83, and rotations in output: 1.2

**DRIVES FOR SPECIAL DOORS WITH CHAIN DRIVE**

				DIAMETER (Ø OUTSIDE) OF THE WINDING SHAFT (MM)											
				101,6	108,0	114,0	133,0	159,0	177,8	193,7	219,1	244,5	273,0	298,5	323,9
<b>KD-50-100-24</b>	Chain Drive Ratio	1:2	Kg	644	613	587	516	443	402	373	334	303	274	252	234
			V (cm/sn)	8,0	8,4	8,7	9,9	11,6	12,7	13,7	15,3	16,9	18,7	20,3	21,9
		1:3	Kg	966	920	880	774	665	603	559	501	454	410	378	351
			V (cm/sn)	5,3	5,6	5,8	6,6	7,7	8,5	9,2	10,2	11,3	12,5	13,5	14,6
		1:3,8	Kg	1224	1165	1115	981	842	764	708	635	575	520	479	444
			V (cm/sn)	4,2	4,4	4,6	5,2	6,1	6,7	7,2	8,1	8,9	9,8	10,7	11,5
1:4,5	Kg	1449	1380	1320	1161	997	905	839	752	681	616	567	526		
	V (cm/sn)	3,5	3,7	3,9	4,4	5,1	5,7	6,1	6,8	7,5	8,3	9,0	9,7		
<b>KD-63-170-24</b>	Chain Drive Ratio	1:2	Kg	438	417	399	351	301	273	254	227	206	186	171	159
			V (cm/sn)	8,0	8,4	8,7	9,9	11,6	12,7	13,7	15,3	16,9	18,7	20,3	21,9
		1:3	Kg	657	625	598	526	452	410	380	341	309	279	257	238
			V (cm/sn)	5,3	5,6	5,8	6,6	7,7	8,5	9,2	10,2	11,3	12,5	13,5	14,6
		1:3,8	Kg	832	792	758	667	573	520	482	432	391	354	326	302
			V (cm/sn)	4,2	4,4	4,6	5,2	6,1	6,7	7,2	8,1	8,9	9,8	10,7	11,5
1:4,5	Kg	986	938	898	790	678	615	571	511	463	419	386	358		
	V (cm/sn)	3,5	3,7	3,9	4,4	5,1	5,7	6,1	6,8	7,5	8,3	9,0	9,7		
<b>KD-85-250-24</b>	Chain Drive Ratio	1:2	Kg				516	443	402	373	334	303	274	252	234
			V (cm/sn)				9,9	11,6	12,7	13,7	15,3	16,9	18,7	20,3	21,9
		1:3	Kg				774	665	603	559	501	454	410	378	351
			V (cm/sn)				6,6	7,7	8,5	9,2	10,2	11,3	12,5	13,5	14,6
		1:3,8	Kg				981	842	764	708	635	575	520	479	444
			V (cm/sn)				5,2	6,1	6,7	7,2	8,1	8,9	9,8	10,7	11,5
1:4,5	Kg				1161	997	905	839	752	681	616	567	526		
	V (cm/sn)				4,4	5,1	5,7	6,1	6,8	7,5	8,3	9,0	9,7		
<b>KD-85-350-24</b>	Chain Drive Ratio	1:2	Kg					620	563	522	468	424	383	353	327
			V (cm/sn)					11,6	12,7	13,7	15,3	16,9	18,7	20,3	21,9
		1:3	Kg					931	844	783	702	635	575	529	491
			V (cm/sn)					7,7	8,5	9,2	10,2	11,3	12,5	13,5	14,6
		1:3,8	Kg					1179	1070	992	889	805	728	671	622
			V (cm/sn)					6,1	6,7	7,2	8,1	8,9	9,8	10,7	11,5
1:4,5	Kg					1396	1267	1175	1052	953	862	794	736		
	V (cm/sn)					5,1	5,7	6,1	6,8	7,5	8,3	9,0	9,7		
<b>KD-85-450-24</b>	Chain Drive Ratio	1:2	Kg					798	724	671	601	545	493	454	421
			V (cm/sn)					11,6	12,7	13,7	15,3	16,9	18,7	20,3	21,9
		1:3	Kg					1197	1086	1007	902	817	739	681	631
			V (cm/sn)					7,7	8,5	9,2	10,2	11,3	12,5	13,5	14,6
		1:3,8	Kg					1516	1375	1275	1143	1035	936	862	799
			V (cm/sn)					6,1	6,7	7,2	8,1	8,9	9,8	10,7	11,5
1:4,5	Kg					1795	1629	1510	1353	1226	1108	1021	947		
	V (cm/sn)					5,1	5,7	6,1	6,8	7,5	8,3	9,0	9,7		

## DRIVES FOR SPECIAL DOORS WITH CHAIN DRIVE

			TDIAMETER (Ø OUTSIDE) OF THE WINDING SHAFT (MM)												
			101,6	108,0	114,0	133,0	159,0	177,8	193,7	219,1	244,5	273,0	298,5	323,9	
<b>KD-110-600-24</b>	Chain Drive Ratio	1:2	Kg					1064	965	895	802	726	657	605	561
		V (cm/sn)					11,6	12,7	13,7	15,3	16,9	18,7	20,3	21,9	
	1:3	Kg					1596	1448	1342	1203	1089	985	908	841	
		V (cm/sn)					7,7	8,5	9,2	10,2	11,3	12,5	13,5	14,6	
	1:3,8	Kg					2021	1834	1700	1523	1380	1248	1150	1066	
		V (cm/sn)					6,1	6,7	7,2	8,1	8,9	9,8	10,7	11,5	
1:4,5	Kg					2393	2171	2014	1804	1634	1478	1361	1262		
	V (cm/sn)					5,1	5,7	6,1	6,8	7,5	8,3	9,0	9,7		
<b>KD-110-800-24</b>	Chain Drive Ratio	1:2	Kg						1287	1193	1069	968	876	807	748
		V (cm/sn)							12,7	13,7	15,3	16,9	18,7	20,3	21,9
	1:3	Kg							1930	1790	1604	1452	1314	1210	1122
		V (cm/sn)							8,5	9,2	10,2	11,3	12,5	13,5	14,6
	1:3,8	Kg							2445	2267	2031	1840	1664	1533	1421
		V (cm/sn)							6,7	7,2	8,1	8,9	9,8	10,7	11,5
1:4,5	Kg							2895	2685	2405	2179	1970	1815	1683	
	V (cm/sn)							5,7	6,1	6,8	7,5	8,3	9,0	9,7	
<b>KD-110-1000-24</b>	Chain Drive Ratio	1:2	Kg						1608	1492	1336	1210	1095	1008	935
		V (cm/sn)							12,7	13,7	15,3	16,9	18,7	20,3	21,9
	1:3	Kg							2413	2237	2004	1816	1642	1513	1402
		V (cm/sn)							8,5	9,2	10,2	11,3	12,5	13,5	14,6
	1:3,8	Kg							3056	2834	2539	2300	2080	1916	1776
		V (cm/sn)							6,7	7,2	8,1	8,9	9,8	10,7	11,5
1:4,5	Kg							3619	3356	3007	2723	2463	2269	2104	
	V (cm/sn)							5,7	6,1	6,8	7,5	8,3	9,0	9,7	

All indicated weights in the table take into account a safety reserve of 20 % and a slat thickness of 25 mm.  
 In some cases, the friction may be greater and this condition should be taken into account when calculating.  
 Their extra friction and possible diameter changes due to over-winding, must be taken into account when calculating these values.

- ↘ If frequency inverter drives are used, increasing the driving speed by 10% will cause a 5% decrease in drive torque. This should be considered when choosing a driver.
- ↘ In gearmotors powered at a frequency of 60Hz (and at the same voltage), multipliers are used for some performance figures: Output torque: 0.83 , and rotations in output: 1.2

Special solutions can be offered upon request. Please contact us for requests in different speeds and powers.

# DIMENSIONS

## KD-50 WITH MK

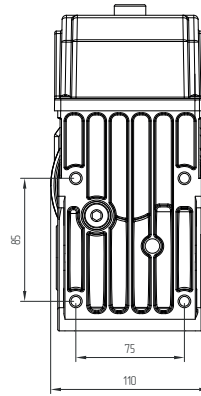
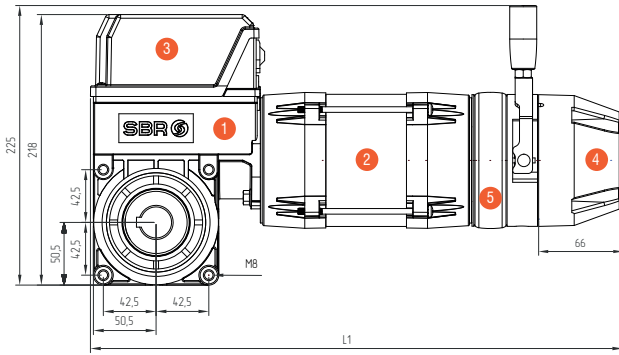

1	Gearbox
2	Motor
3	Limit Switch
4	Hand Crank MK
5	Brake

KD SERIES	L1
KD-50-100-24	410

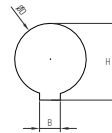
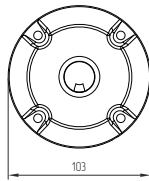
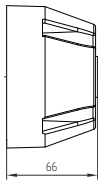

ØD	H	B
D25.0	28,3	8,00

## KD-50 WITH C2

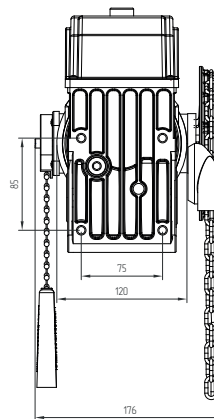
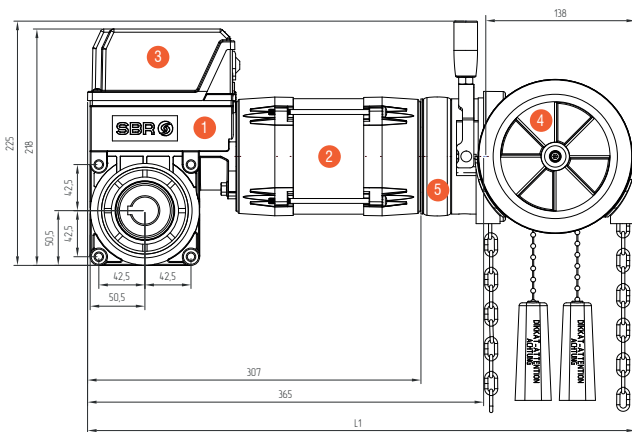

1	Gearbox
2	Motor
3	Limit Switch
4	Hand Crank C2
5	Brake

KD SERIES	L1
KD-50-100-24	463

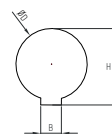
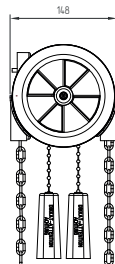
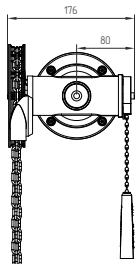

ØD	H	B
D25.0	28,3	8,00

## DIMENSIONS

### KD-63 WITH MK

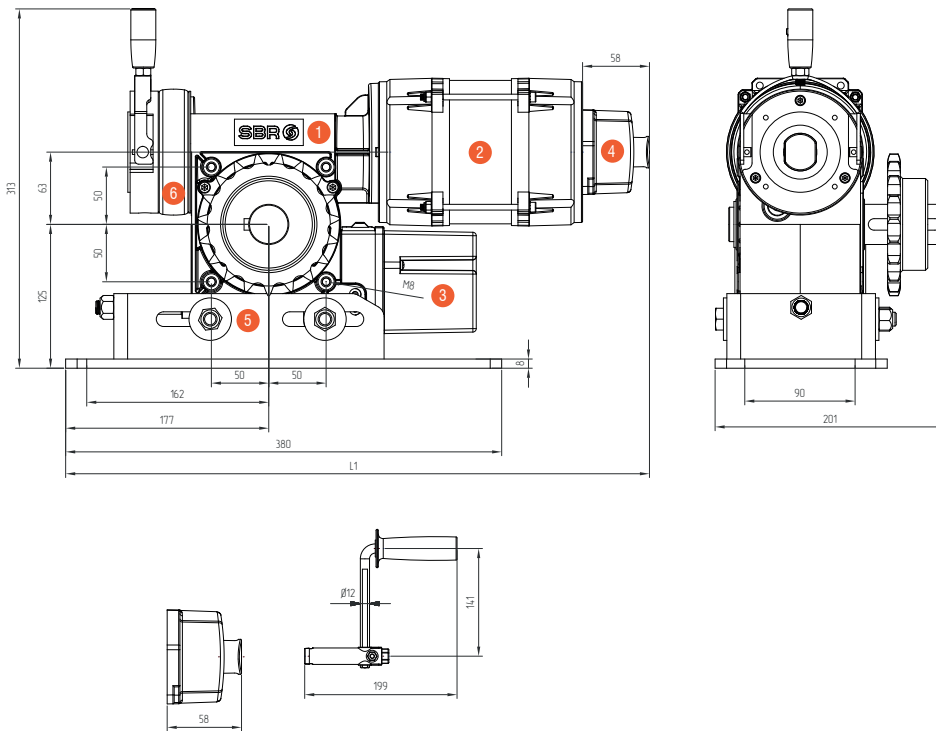

1	Gearbox
2	Motor
3	Limit Switch
4	Hand Crank MK
5	Floating Foot
6	Brake

KD SERIES	L1
KD-63-170-24	455

ØD	H	B
D30.0	33,3	8,00

### KD-63 WITH C2

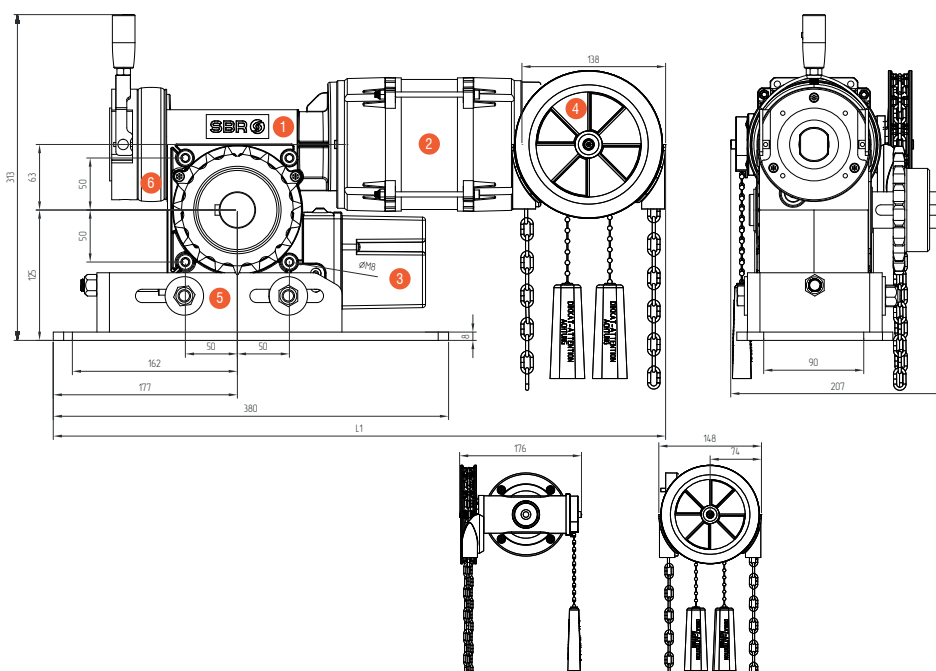

1	Gearbox
2	Motor
3	Limit Switch
4	Hand Crank C2
5	Floating Foot
6	Brake

KD SERIES	L1
KD-63-170-24	534

ØD	H	B
D30.0	33,3	8,00



# DIMENSIONS

## KD-85 WITH MK

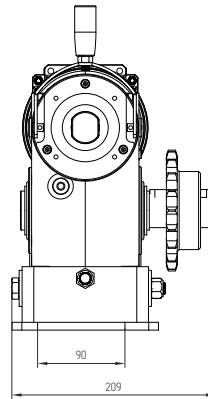
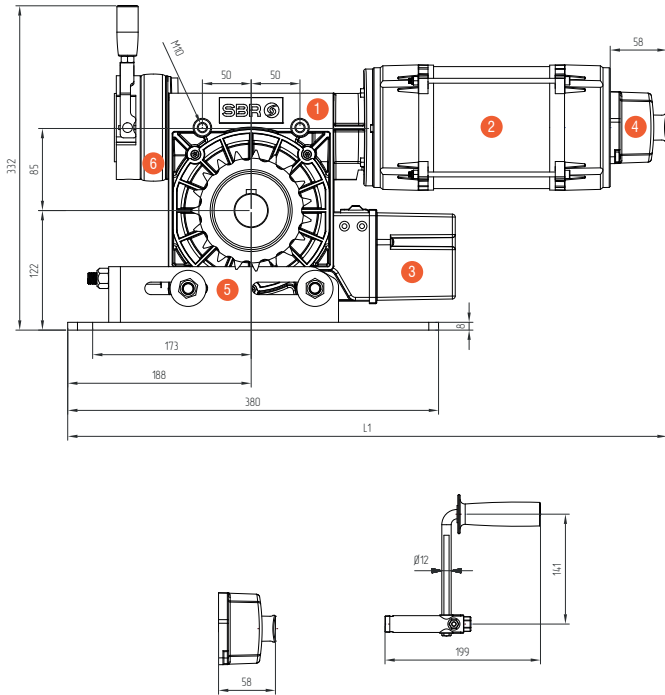

1	Gearbox
2	Motor
3	Limit Switch
4	Hand Crank MK
5	Floating Foot
6	Brake

KD SERIES	L1
KD-85-250-24	539
KD-85-350-24	568
KD-85-450-24	614

ØD	H	B
D40.0	43,3	12,00

## KD-85 WITH C2

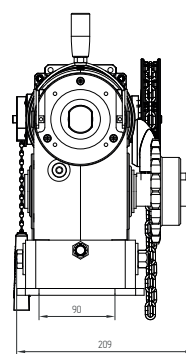
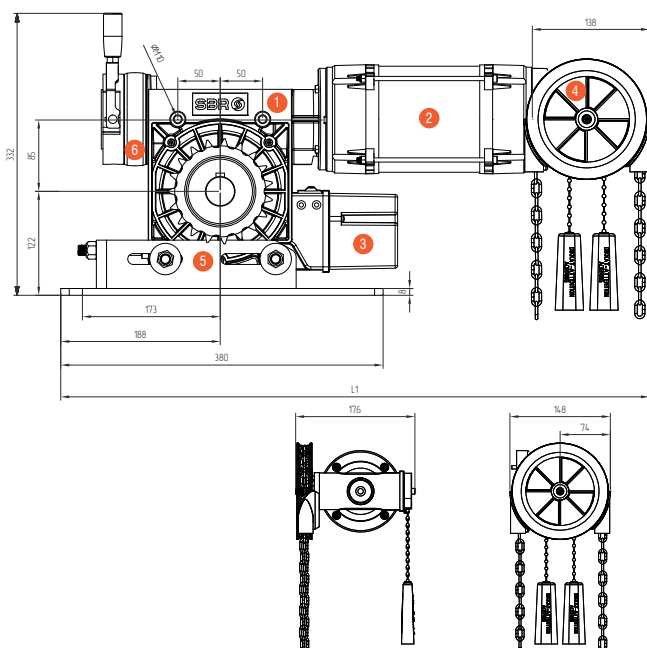

1	Gearbox
2	Motor
3	Limit Switch
4	Hand Crank C2
5	Floating Foot
6	Brake

KD SERIES	L1
KD-85-250-24	619
KD-85-350-24	648
KD-85-450-24	694

ØD	H	B
D40.0	43,3	12,00

# DIMENSIONS

## KD-110 WITH MK

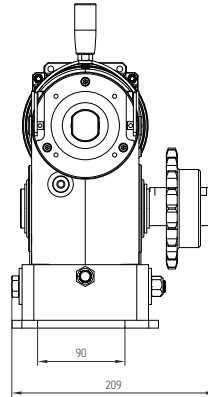
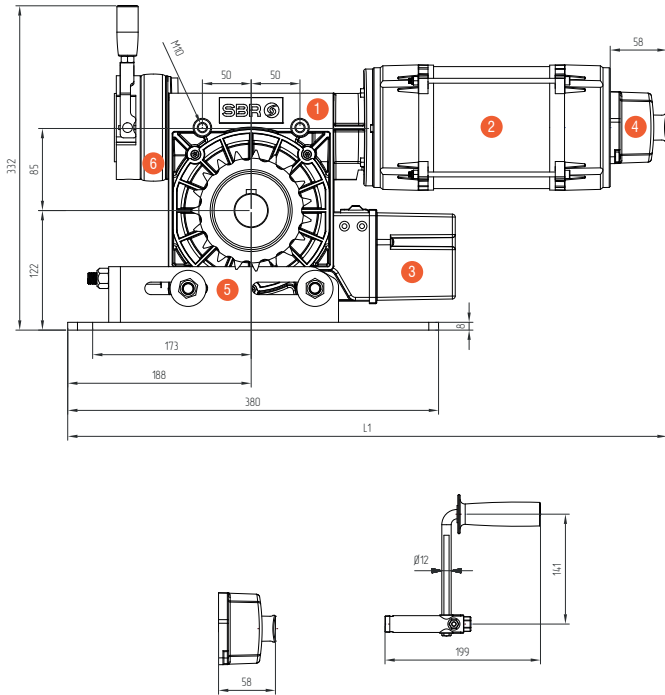

1	Gearbox
2	Motor
3	Limit Switch
4	Hand Crank MK
5	Floating Foot
6	Brake

KD SERIES	L1
KD-110-600-24	711
KD-110-750-24	715
KD-110-1000-24	715

ØD	H	B
D55.0	64,4	16,00

## KD-110 WITH C2

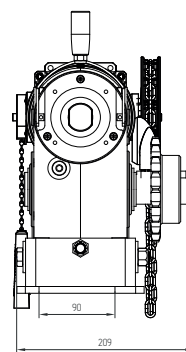
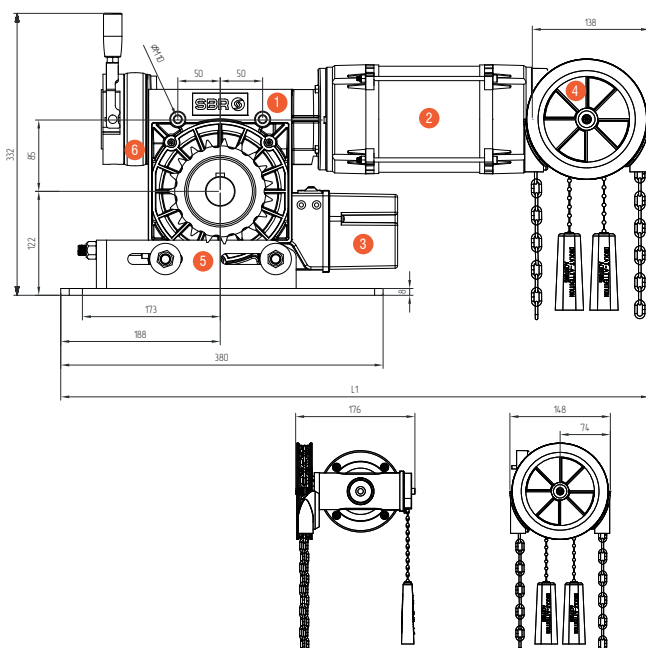

1	Gearbox
2	Motor
3	Limit Switch
4	Hand Crank C2
5	Floating Foot
6	Brake

KD SERIES	L1
KD-110-600-24	791
KD-110-750-24	794
KD-110-1000-24	794

ØD	H	B
D55.0	64,4	16,00

**CONTROL UNIT** ST - EP - FI - FE SERIES

# CONTROL SYSTEMS



ST SERIES  
EP SERIES  
FE SERIES  
FU SERIES  
FI SERIES

## ST 400



### Technical Data

- For SBR SD/DS/RD/PS/KD operators with ENC or MEC. (Up to 1,50 kW)
- Supply voltage: 3N~400V AC
- Operating Frequency: 50 Hz / 60 Hz
- Control Voltage: 24 V DC
- Supply voltage for external devices: 24 V DC (0,25 A)
- Operating Temperatures: -10 / +45 °C

### Cover

- Dimensions W x H x D [mm]:
- IP 54 Protection class
- Protection against contact is provided by covers for live parts for electrical shock hazard.

### Design

- Illuminated OPEN-STOP-CLOSE buttons
- LCD screen for easy adjustment
- Extension module connections

### Accessories

- Extension accessories:
  - Relay module (yellow-red-green traffic lights and 3 programmable relays)
  - Receiver module (2 channel 433 MHz)

### Functions

- Limit position adjustment (ENC only) and adjustment of all parameters from user level
- Selectable operating modes;
  - OPEN/CLOSE in self hold mode
  - OPEN in self hold / CLOSE in hold to run mode
  - OPEN/CLOSE in hold to run mode
- Time adjustable automatic closing.
- Adjustable partial opening.
- Safety systems :
  - Photocell (NC)
  - Optical sensor (NC or NO)
  - Pneumatic sensor (NC or NO)
- Adjustable return time (for both direction change).
- Strain detection.
- LCD screen for information and status monitoring.
- Door Operation-cycle counter (not resettable).
- Maintenance-cycle counter;
  - Value interval
  - Visual warning when reached to value or transition to hold to run operating mode.
- Extension accessories:
  - Relay module (yellow-red-green traffic lights and 3 programmable relays)
  - Receiver module (2 channel 433 MHz)
- Internal error memory.

## EP 400



### Technical Data

- For SBR SD/DS/RD/KD operators with ENC or MEC. (Up to 0,75 kW)
- Supply voltage: 3N~400V AC
- Operating Frequency: 50 Hz / 60 Hz
- Control Voltage: 24 V DC
- Supply voltage for external devices: 24 V DC (0,25 A)
- Operating Temperatures: -10 / +45 °C

### Cover

- Dimensions W x H x D [mm]:
- IP 54 Protection class
- Protection against contact is provided by covers for live parts for electrical shock hazard.

### Design

- Illuminated OPEN-STOP-CLOSE buttons
- LCD screen for easy adjustment
- Programmable relay output

### Functions

- Limit position adjustment (ENC only) and adjustment of all parameters from user level
- Selectable operating modes;
  - OPEN/CLOSE in self hold mode
  - OPEN in self hold / CLOSE in hold to run mode
  - OPEN/CLOSE in hold to run mode
- Time adjustable automatic closing. (Function can also be activated/deactivated).
  - When door reaches the open position, the door closes automatically after the set time.
  - Counter restarts after photocell activity.
- Safety systems;
  - Photocell (NC)
  - Optical sensor (NC or NO)
  - Pneumatic sensor (NC or NO)
- Adjustable return time (for both direction change).
- Strain detection.
- LCD screen for information and status monitoring.
- Door Operation-cycle counter (not resettable).
- Maintenance-cycle counter;
  - Value interval:
  - Visual warning when reached to value or transition to hold to run operating mode.
- Extension accessories:
  - Relay module (yellow-red-green traffic lights and 3 programmable relays)
- Internal error memory.

## EP 500



### Technical Data

- For SBR SD/DS/RD/PS/KD operators with ENC or MEC. (Up to 1,50 kW)
- Supply voltage: 3N~400V AC
- Operating Frequency: 50 Hz / 60 Hz
- Control Voltage: 24 V DC
- Supply voltage for external devices: 24 V DC (0,30 A)
- Operating Temperatures: -10 / +45 °C

### Cover

- Dimensions W x H x D [mm]:
- IP 54 Protection class

### Design

- Illuminated OPEN-STOP-CLOSE buttons
- LCD screen for easy adjustment with 3 buttons
- Emergency stop button

### Functions:

- Limit position adjustment (ENC only) and adjustment of all parameters from user level
- Selectable operating modes;
  - OPEN/CLOSE in self hold mode
  - OPEN in self hold / CLOSE in hold to run mode
  - OPEN/CLOSE in hold to run mode
- Time adjustable automatic closing.
- Adjustable partial opening.
- Safety systems;
  - Photocell (NC)
  - Optical sensor (NC or NO)
  - Pneumatic sensor (NC or NO)
- Adjustable return time (for both direction change).
- Strain detection.
- LCD screen for information and status monitoring.
- Door Operation-cycle counter (not resettable).
- Maintenance-cycle counter;
  - Value interval
  - Visual warning when reached to value or transition to hold to run operating mode.
- Internal error memory.

## FE 500



### Technical Data

- For SBR SD/DS/RD/KD operators with ENC or MEC. (Up to 2,20 kW)
- Supply voltage: 3N~400V AC
- Operating Frequency: 50 Hz / 60 Hz
- Control Voltage: 24 V DC
- Supply voltage for external devices: 24 V DC (0,30 A)
- Operating Temperatures: -10 / +45 °C

### Cover

- Dimensions W x H x D [mm]:
- IP 54 Protection class

### Design

- Illuminated OPEN-STOP-CLOSE buttons
- LCD screen for easy adjustment
- Emergency stop button

### Functions

- Limit position adjustment (ENC only) and adjustment of all parameters from user level
- Selectable operating modes;
  - OPEN/CLOSE in self hold mode
  - OPEN in self hold / CLOSE in hold to run mode
  - OPEN/CLOSE in hold to run mode
- Time adjustable automatic closing.
- Adjustable partial opening.
- Emergency stop button.
- Safety systems;
  - Photocell (NC)
  - Optical sensor (NC or NO)
  - Pneumatic sensor (NC or NO)
- Adjustable return time (for both direction change).
- Strain detection.
- LCD screen for information and status monitoring.
- Door Operation-cycle counter (not resettable).
- Maintenance-cycle counter;
  - Value interval:
  - Visual warning when reached to value or transition to hold to run operating mode.
- Internal error memory.

## EP 450 RP



### Technical Data

- For SBR SD/DS/RD/PS/KD operators with ENC or MEC. (Up to 0,75 kW)
- Supply voltage: 3N~400V AC
- Operating Frequency: 50 Hz / 60 Hz
- Control Voltage: 24 V DC
- Supply voltage for external devices: 24 V DC (0,25 A)
- Operating Temperatures: -10 / +45 °C

### Cover

- Dimensions W x H x D [mm]:
- IP 54 Protection class
- Protection against contact is provided by covers for live parts for electrical shock hazard.

### Design

- Illuminated OPEN-STOP-CLOSE buttons
- LCD screen for easy adjustment with 3 buttons
- Controlling dock leveler with swing lip

### Functions:

- Limit position adjustment (ENC only) and adjustment of all parameters from user level
- Selectable operating modes;
  - OPEN/CLOSE in self hold mode
  - OPEN in self hold / CLOSE in hold to run mode
  - OPEN/CLOSE in hold to run mode
- Time adjustable automatic closing (function can also be activated/deactivated).
  - When door reaches the open position, the door closes automatically after the set time.
  - Counter restarts after photocell activity.
- Safety systems;
  - Photocell (NC)
  - Optical sensor (NC or NO)
  - Pneumatic sensor (NC or NO)
- Adjustable return time (for both direction change).
- Strain detection.
- LCD screen for information and status monitoring.
- Door Operation-cycle counter (not resettable).
- Maintenance-cycle counter;
  - Value interval
  - Visual warning when reached to value or transition to hold to run operating mode.
- Internal error memory.

## EP 450 TRP



### Technical Data

- For SBR SD/DS/RD/PS/KD operators with ENC or MEC. (Up to 0,75 kW)
- Supply voltage: 3N~400V AC
- Operating Frequency: 50 Hz / 60 Hz
- Control Voltage: 24 V DC
- Supply voltage for external devices: 24 V DC (0,25 A)
- Operating Temperatures: -10 / +45 °C

### Cover

- Dimensions W x H x D [mm]:
- IP 54 Protection class
- Protection against contact is provided by covers for live parts for electrical shock hazard.

### Design

- Illuminated OPEN-STOP-CLOSE buttons
- LCD screen for easy adjustment with 3 buttons
- Controlling dock leveler with swing lip

### Functions:

- Limit position adjustment (ENC only) and adjustment of all parameters from user level
- Selectable operating modes;
  - OPEN/CLOSE in self hold mode
  - OPEN in self hold / CLOSE in hold to run mode
  - OPEN/CLOSE in hold to run mode
- Time adjustable automatic closing (function can also be activated/deactivated).
  - When door reaches the open position, the door closes automatically after the set time.
  - Counter restarts after photocell activity.
- Safety systems;
  - Photocell (NC)
  - Optical sensor (NC or NO)
  - Pneumatic sensor (NC or NO)
- Adjustable return time (for both direction change).
- Strain detection.
- LCD screen for information and status monitoring.
- Door Operation-cycle counter (not resettable).
- Maintenance-cycle counter;
  - Value interval
  - Visual warning when reached to value or transition to hold to run operating mode.
- Internal error memory.

## FE 5XX



### Technical Data

- For SBR SD/DS/RD/PS/KD operators with ENC or MEC.
- Supply voltage: 3N~400V AC
- Operating Frequency: 50 Hz / 60 Hz
- Control Voltage: 24 V DC
- Supply voltage for external devices: 24 V DC (0,30 A)
- Operating Temperatures: -10 / +45 °C

### Cover

- Dimensions W x H x D [mm]:
- IP 54 Protection class

### Design

- Illuminated OPEN-STOP-CLOSE-PARTIAL OPEN buttons
- LCD screen for easy adjustment with 3 buttons
- Emergency stop button

### Products

- FE 530 - Up to 0,75 kW
- FE 540 - Up to 1,50 kW
- FE 550 - Up to 2,20 kW
- FE 560 - Up to 4,00 kW
- FE 570 - Up to 5,50 kW

### Functions:

- Limit position adjustment (ENC only) and adjustment of all parameters from user level
- Selectable operating modes;
  - OPEN/CLOSE in self hold mode
  - OPEN in self hold / CLOSE in hold to run mode
  - OPEN/CLOSE in hold to run mode
- Time adjustable automatic closing
- Adjustable partial opening.
- Emergency stop button.
- Safety systems;
  - Photocell (NC)
  - Optical sensor (NC or NO)
  - Pneumatic sensor (NC or NO)
- Adjustable return time (for both direction change).
- Strain detection.
- LCD screen for information and status monitoring.
- Door Operation-cycle counter (not resettable).
- Maintenance-cycle counter;
  - Value interval
  - Visual warning when reached to value or transition to hold to run operating mode.
- Internal error memory.

## FU 750 M



### Technical Data

- For SBR SD operators with ENC or MEC.  
(Up to 0,75 kW)
- Supply voltage: 1N~230V AC
- Operating Frequency: 50 Hz / 60 Hz
- Control Voltage: 24 V DC
- Supply voltage for external devices: 24 V DC (0,30 A)
- Operating Temperatures: -10 / +45 °C

### Cover

- Dimensions W x H x D [mm]:
- IP 54 Protection class

### Design

- Illuminated OPEN-STOP-CLOSE-PARTIAL OPEN buttons
- LCD screen for easy adjustment with 3 buttons
- Emergency stop button
- Speed control

### Functions:

- Limit position adjustment (ENC only) and adjustment of all parameters from user level
- Selectable operating modes;
  - OPEN/CLOSE in self hold mode
  - OPEN in self hold / CLOSE in hold to run mode
  - OPEN/CLOSE in hold to run mode
- Time adjustable automatic closing
- Adjustable partial opening.
- Emergency stop button.
- Safety systems;
  - Photocell (NC)
  - Optical sensor (NC or NO)
  - Pneumatic sensor (NC or NO)
- Adjustable return time (for both direction change).
- Speed adjustment;
  - OPENING/CLOSING speed can be adjusted separately.
  - Adjustable deceleration range.
  - Soft start / soft stop.
- Strain detection.
- LCD screen for information and status monitoring.
- Door Operation-cycle counter (not resettable).
- Maintenance-cycle counter;
  - Value interval
  - Visual warning when reached to value or transition to hold to run operating mode.
- Internal error memory.

## FI 750 M



### Technical Data

- For SBR DS/RD/PS/KD operators with ENC or MEC. (Up to 0,75 kW)
- Supply voltage: 1N~230V AC
- Operating Frequency: 50 Hz / 60 Hz
- Control Voltage: 24 V DC
- Supply voltage for external devices: 24 V DC (0,30 A)
- Operating Temperatures: -10 / +45 °C

### Cover

- Dimensions W x H x D [mm]:
- IP 54 Protection class

### Design

- Illuminated OPEN-STOP-CLOSE-PARTIAL OPEN buttons
- LCD screen for easy adjustment with 3 buttons
- Emergency stop button
- Speed control

### Functions:

- Limit position adjustment (ENC only) and adjustment of all parameters from user level
- Selectable operating modes;
  - OPEN/CLOSE in self hold mode
  - OPEN in self hold / CLOSE in hold to run mode
  - OPEN/CLOSE in hold to run mode
- Time adjustable automatic closing
- Adjustable partial opening.
- Emergency stop button.
- Safety systems;
  - Photocell (NC)
  - Optical sensor (NC or NO)
  - Pneumatic sensor (NC or NO)
- Adjustable return time (for both direction change).
- Speed adjustment;
  - OPENING/CLOSING speed can be adjusted separately.
  - Adjustable deceleration range.
  - Soft start / soft stop.
- Strain detection.
- LCD screen for information and status monitoring.
- Door Operation-cycle counter (not resettable).
- Maintenance-cycle counter;
  - Value interval
  - Visual warning when reached to value or transition to hold to run operating mode.
- Internal error memory.

## FI 1500 M



### Technical Data

- For SBR DS/RD/PS/KD operators with ENC or MEC. (Up to 0,75 kW)
- Supply voltage: 1N~230V AC
- Operating Frequency: 50 Hz / 60 Hz
- Control Voltage: 24 V DC
- Supply voltage for external devices: 24 V DC (0,30 A)
- Operating Temperatures: -10 / +45 °C

### Cover

- Dimensions W x H x D [mm]:
- IP 54 Protection class

### Design

- Illuminated OPEN-STOP-CLOSE-PARTIAL OPEN buttons
- LCD screen for easy adjustment with 3 buttons
- Emergency stop button
- Speed control

### Functions:

- Limit position adjustment (ENC only) and adjustment of all parameters from user level
- Selectable operating modes;
  - OPEN/CLOSE in self hold mode
  - OPEN in self hold / CLOSE in hold to run mode
  - OPEN/CLOSE in hold to run mode
- Time adjustable automatic closing
- Adjustable partial opening.
- Emergency stop button.
- Safety systems;
  - Photocell (NC)
  - Optical sensor (NC or NO)
  - Pneumatic sensor (NC or NO)
- Adjustable return time (for both direction change).
- Speed adjustment;
  - OPENING/CLOSING speed can be adjusted separately.
  - Adjustable deceleration range.
  - Soft start / soft stop.
- Strain detection.
- LCD screen for information and status monitoring.
- Door Operation-cycle counter (not resettable).
- Maintenance-cycle counter;
  - Value interval
  - Visual warning when reached to value or transition to hold to run operating mode.
- Internal error memory.



## FI 1500 T



### Technical Data

- For SBR DS/RD/PS/KD operators with ENC or MEC. (Up to 1,50 kW)
- Supply voltage: 3N~400V AC
- Operating Frequency: 50 Hz / 60 Hz
- Control Voltage: 24 V DC
- Supply voltage for external devices: 24 V DC (0,30 A)
- Operating Temperatures: -10 / +45 °C

### Cover

- Dimensions W x H x D [mm]:
- IP 54 Protection class

### Design

- Illuminated OPEN-STOP-CLOSE-PARTIAL OPEN buttons
- LCD screen for easy adjustment with 3 buttons
- Emergency stop button
- Speed control

### Functions:

- Limit position adjustment (ENC only) and adjustment of all parameters from user level
- Selectable operating modes;
  - OPEN/CLOSE in self hold mode
  - OPEN in self hold / CLOSE in hold to run mode
  - OPEN/CLOSE in hold to run mode
- Time adjustable automatic closing
- Adjustable partial opening.
- Emergency stop button.
- Safety systems;
  - Photocell (NC)
  - Optical sensor (NC or NO)
  - Pneumatic sensor (NC or NO)
- Adjustable return time (for both direction change).
- Speed adjustment;
  - OPENING/CLOSING speed can be adjusted separately.
  - Adjustable deceleration range.
  - Soft start / soft stop.
- Strain detection.
- LCD screen for information and status monitoring.
- Door Operation-cycle counter (not resettable).
- Maintenance-cycle counter;
  - Value interval
  - Visual warning when reached to value or transition to hold to run operating mode.
- Internal error memory.

## FI 2200 T



### Technical Data

- For SBR DS/RD/PS/KD operators with ENC or MEC. (Up to 2,0 kW)
- Supply voltage: 3N~400V AC
- Operating Frequency: 50 Hz / 60 Hz
- Control Voltage: 24 V DC
- Supply voltage for external devices: 24 V DC (0,30 A)
- Operating Temperatures: -10 / +45 °C

### Cover

- Dimensions W x H x D [mm]:
- IP 54 Protection class

### Design

- Illuminated OPEN-STOP-CLOSE-PARTIAL OPEN buttons
- LCD screen for easy adjustment with 3 buttons
- Emergency stop button
- Speed control

### Functions:

- Limit position adjustment (ENC only) and adjustment of all parameters from user level
- Selectable operating modes;
  - OPEN/CLOSE in self hold mode
  - OPEN in self hold / CLOSE in hold to run mode
  - OPEN/CLOSE in hold to run mode
- Time adjustable automatic closing
- Adjustable partial opening.
- Emergency stop button.
- Safety systems;
  - Photocell (NC)
  - Optical sensor (NC or NO)
  - Pneumatic sensor (NC or NO)
- Adjustable return time (for both direction change).
- Speed adjustment;
  - OPENING/CLOSING speed can be adjusted separately.
  - Adjustable deceleration range.
  - Soft start / soft stop.
- Strain detection.
- LCD screen for information and status monitoring.
- Door Operation-cycle counter (not resettable).
- Maintenance-cycle counter;
  - Value interval
  - Visual warning when reached to value or transition to hold to run operating mode.
- Internal error memory.

## FI 4000 T



### Technical Data

- For SBR DS/RD/PS/KD operators with ENC or MEC. (Up to 4,00 kW)
- Supply voltage: 3N~400V AC
- Operating Frequency: 50 Hz / 60 Hz
- Control Voltage: 24 V DC
- Supply voltage for external devices: 24 V DC (0,30 A)
- Operating Temperatures: -10 / +45 °C

### Cover

- Dimensions W x H x D [mm]:
- IP 54 Protection class

### Design

- Illuminated OPEN-STOP-CLOSE-PARTIAL OPEN buttons
- LCD screen for easy adjustment with 3 buttons
- Emergency stop button
- Speed control

### Functions:

- Limit position adjustment (ENC only) and adjustment of all parameters from user level
- Selectable operating modes;
  - OPEN/CLOSE in self hold mode
  - OPEN in self hold / CLOSE in hold to run mode
  - OPEN/CLOSE in hold to run mode
- Time adjustable automatic closing
- Adjustable partial opening.
- Emergency stop button.
- Safety systems;
  - Photocell (NC)
  - Optical sensor (NC or NO)
  - Pneumatic sensor (NC or NO)
- Adjustable return time (for both direction change).
- Speed adjustment;
  - OPENING/CLOSING speed can be adjusted separately.
  - Adjustable deceleration range.
  - Soft start / soft stop.
- Strain detection.
- LCD screen for information and status monitoring.
- Door Operation-cycle counter (not resettable).
- Maintenance-cycle counter;
  - Value interval
  - Visual warning when reached to value or transition to hold to run operating mode.
- Internal error memory.



SUITABLE SERIES	SD DS RD PS KD	SD DS RD KD	SD DS RD PS KD	SD DS RD PS KD	SD DS RD PS KD	SD DS RD PS KD
-----------------	----------------------------	----------------------	----------------------------	----------------------------	----------------------------	----------------------------

Operating Voltage	3N~400 V AC	3N~400 V AC	3N~400 V AC	3N~400 V AC	3N~400 V AC	3N~400 V AC
Operating Frequency	50/60 Hz	50/60 Hz	50/60 Hz	50/60 Hz	50/60 Hz	50/60 Hz
Max Motor Power	1,50 kW	0,75 kW	1,50 kW	2,20 kW	0,75 kW	0,75 kW
Control Voltage	24 V	24 V	24 V	24 V	24 V	24 V
24V Output Supply	24 V Dc Max 0,25 A	24 V Dc Max 0,30 A	24 V Dc Max 0,30 A	24 V Dc Max 0,30 A	24 V Dc Max 0,30 A	24 V Dc Max 0,30 A
Temperature Range	-10 / +45	-10 / +45	-10 / +45	-10 / +45	-10 / +45	-10 / +45
Digital Screen	●	●	●	●	●	●
End Position Setting	E/M	E/M	E/M	E/M	E/M	E/M
Adjustable Opening/Closing Speed						
Soft Start/Stop						
Illuminated Buttons (Find In The Dark)	●	●	●	●	●	●
Emergency Stop Button			●	●	●	●
"Connection For Safety Edge System (Photocell, Optical Sensor, Air Pressure)"	●	●	●	●	●	●
Programmable Relay Outputs	OP	●	●	●	●	●
Remote Receiver Module Connections	●	●	●	●	●	●
Partial Opening Button						
Expansion Module Support (Relay Module, Receiver Module)	● / ●					
Controlling A Dock Leveller With Swing Lip					●	
Controlling A Dock Leveller With Telescoping Lip						●
Integrated Door Operation Counter	●	●	●	●	●	●
Integrated Error Memory	●	●	●	●	●	●

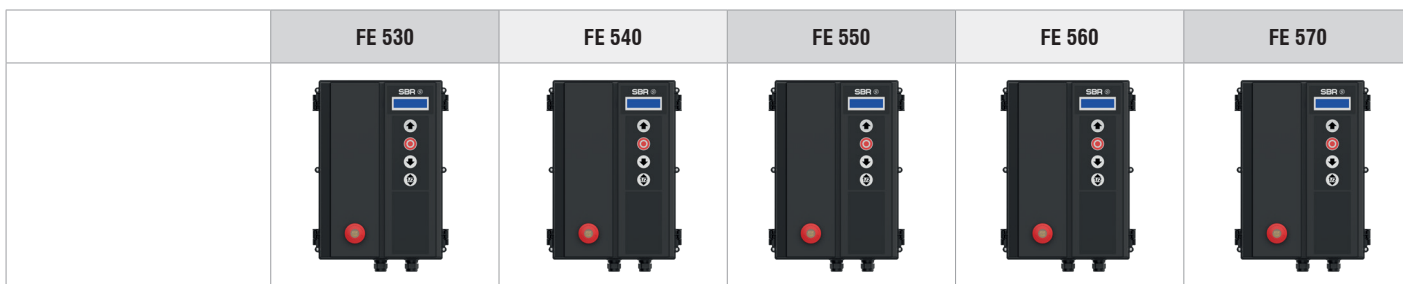

SUITABLE SERIES	SD DS RD PS KD	SD DS RD PS KD	SD DS RD PS KD	SD DS RD PS KD	SD DS RD PS KD
-----------------	----------------------------	----------------------------	----------------------------	----------------------------	----------------------------

Operating Voltage	3N~400 V AC	3N~400 V AC	3N~400 V AC	3N~400 V AC	3N~400 V AC
Operating Frequency	50/60 Hz	50/60 Hz	50/60 Hz	50/60 Hz	50/60 Hz
Max Motor Power	0,75 kW	1,50 kW	2,20 kW	4,00 kW	5,50 kW
Control Voltage	24 V	24 V	24 V	24 V	24 V
24V Output Supply	24 V Dc Max 0,30 A	24 V Dc Max 0,30 A	24 V Dc Max 0,30 A	24 V Dc Max 0,30 A	24 V Dc Max 0,30 A
Temperature Range	-10 / +45	-10 / +45	-10 / +45	-10 / +45	-10 / +45
Digital Screen	●	●	●	●	●
End Position Setting	E/M	E/M	E/M	E/M	E/M
Adjustable Opening/Closing Speed					
Soft Start/Stop					
Illuminated Buttons (Find In The Dark)	●	●	●	●	●
Emergency Stop Button	●	●	●	●	●
"Connection For Safety Edge System (Photocell, Optical Sensor, Air Pressure)"	●	●	●	●	●
Programmable Relay Outputs	●	●	●	●	●
Remote Receiver Module Connections	●	●	●	●	●
Partial Opening Button	●	●	●	●	●
Expansion Module Support (Relay Module, Receiver Module)					
Controlling A Dock Leveller With Swing Lip					
Controlling A Dock Leveller With Telescoping Lip					
Integrated Door Operation Counter	●	●	●	●	●
Integrated Error Memory	●	●	●	●	●

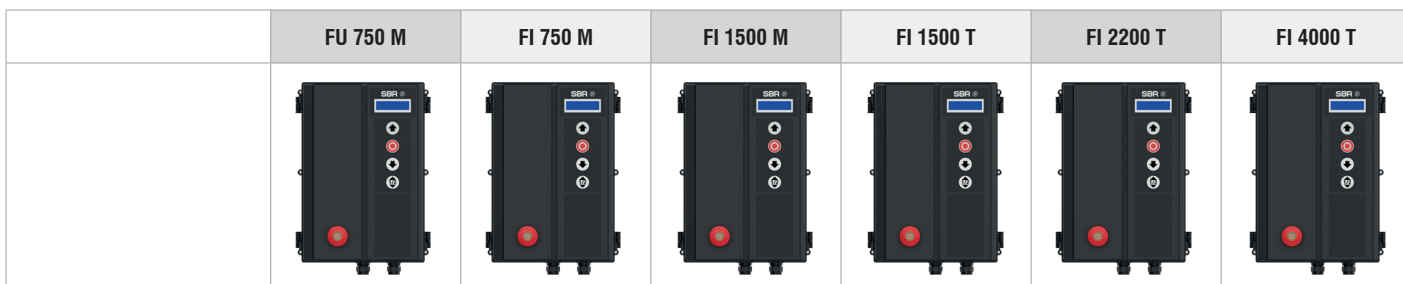

SUITABLE SERIES	SD	DS RD PS KD	DS RD PS KD	DS RD PS KD	DS RD PS KD	DS RD PS KD

Operating Voltage	1N~230 V AC	1N~230 V AC	1N~230 V AC	3N~400 V AC	3N~400 V AC	3N~400 V AC
Operating Frequency	50/60 Hz	50/60 Hz	50/60 Hz	50/60 Hz	50/60 Hz	50/60 Hz
Max Motor Power	0,75 kW	0,75 kW	1,50 kW	1,50 kW	2,20 kW	4,00 kW
Control Voltage	24 V	24 V	24 V	24 V	24 V	24 V
24V Output Supply	24 V Dc Max 0,30 A	24 V Dc Max 0,30 A	24 V Dc Max 0,30 A	24 V Dc Max 0,30 A	24 V Dc Max 0,30 A	24 V Dc Max 0,30 A
Temperature Range	-10 / +45	-10 / +45	-10 / +45	-10 / +45	-10 / +45	-10 / +45
Digital Screen	●	●	●	●	●	●
End Position Setting	E/M	E/M	E/M	E/M	E/M	E/M
Adjustable Opening/Closing Speed	●	●	●	●	●	●
Soft Start/Stop	●	●	●	●	●	●
Illuminated Buttons (Find In The Dark)	●	●	●	●	●	●
Emergency Stop Button	●	●	●	●	●	●
"Connection For Safety Edge System (Photocell, Optical Sensor, Air Pressure)"	●	●	●	●	●	●
Programmable Relay Outputs	●	●	●	●	●	●
Remote Receiver Module Connections	●	●	●	●	●	●
Partial Opening Button	●	●	●	●	●	●
Expansion Module Support (Relay Module, Receiver Module)						
Controlling A Dock Leveller With Swing Lip						
Controlling A Dock Leveller With Telescoping Lip						
Integrated Door Operation Counter	●	●	●	●	●	●
Integrated Error Memory	●	●	●	●	●	●



Fevzi akmak Mah. Sıla Cad. No:48/O Seluklu/KONYA/TURKİYE

+90 332 238 41 82 | info@sbr.com.tr - export@sbr.com.tr

