

# DS SERIES

## NON BALANCED SECTIONAL DOORS DRIVES



# DS-NON BALANCED SECTIONAL DOOR DRIVES

		DS-50-140-20	DS-63-170-24	DS-63-200-19	DS-85-250-24	DS-85-350-24
--	--	--------------	--------------	--------------	--------------	--------------

## Mechanical Properties

Output Torque	Nm	140	170	200	250	350
Output Speed	rpm	20	24	19	24	24
Output Shaft <sup>1</sup>	mm	25,4 31,75	25,0 25,4 30,0 31,75	25,0 25,4 30,0 31,75	30,0 31,75 40,0	30,0 31,75 40,0
Max. Cycles Per Hour <sup>2</sup>	h	8	10	10	11	11
Limit Switch Range	rev	20	20	20	20	20
Max. Output Speed OPEN / CLOSE For Frequency Inverter Operation	rpm	34 / 20	42 / 24	32 / 24	42 / 30	42 / 30

## Electrical Properties

Motor Power	kW	0,55	0,75	0,75	0,75	1,10
Operating Voltage	V	3N~400	3N~400	3N~400	3N~400	3N~400
Operating Frequency	Hz	50/60	50/60	50/60	50/60	50/60
Operating Current <sup>4</sup>	A	3,9/2,3	4,4/2,6	4,6/2,7	4,6/2,7	5,6/3,3
Fuse Protection, On Site	A	10	10	10	10	10
Duty Types	ED	S3-%60	S3-%60	S3-%60	S3-%60	S3-%60
IP Protection Class	IP	54	54	54	54	54
Temperature Range <sup>5</sup>	°C	-20 40 (+60)	-20 +40 (+60)	-20 +40 (+60)	-20 +40 (+60)	-20 +40 (+60)
Working Noise Level	dB (A)	< 70	< 70	< 70	< 70	< 70

## Application

		kg	cm/sn	kg	cm/sn	kg	cm/sn	kg	cm/sn	kg	cm/sn
Sectional Doors Cable Drum [mm] <sup>A</sup>	FF NL 18	177	15,2	215	18,2	253	14,4	316	18,2	443	18,2
	F-160	161	16,7	195	20,1	229	15,9	287	20,1	401	20,1
	F-200	128	20,9	156	25,1	183	19,9	229	25,1	321	25,1

Roller Shutters Tube EN 10220 [mm] <sup>B</sup>	101,6	180	219	258	322	451
	108,0	172	208	245	307	429
	114,3	164	199	234	293	410
	133,0	145	175	206	258	361
	159,0	124	208	245	307	429
	177,8	--	137	161	201	281
	193,7	--	--	149	186	261
	219,1	--	--	--	167	234

Maximum suspended weight in kg

		DS-85-450-24	DS-85-600-15	DS-110-600-24	DS-110-800-24-HD	DS-110-1000-24-HD
--	--	--------------	--------------	---------------	------------------	-------------------

## Mechanical Properties

Property	Unit	DS-85-450-24	DS-85-600-15	DS-110-600-24	DS-110-800-24-HD	DS-110-1000-24-HD
Output Torque	Nm	450	600	600	800	1000
Output Speed	rpm	24	15	24	24	24
Output Shaft <sup>1</sup>	mm	30,0 31,75 40,0	40,0	55,0	55,0	55,0
Max. Cycles Per Hour <sup>2</sup>	h	11	9	7	8	7
Limit Switch Range	rev	20	20	20	20	20
Max. Output Speed OPEN / CLOSE For Frequency Inverter Operation	rpm	42 / 30	26 / 18	42 / 30	42 / 30	34 / 24

## Electrical Properties

Property	Unit	DS-85-450-24	DS-85-600-15	DS-110-600-24	DS-110-800-24-HD	DS-110-1000-24-HD
Motor Power	kW	1,5	1,1	1,5	2,2	3,0
Operating Voltage	V	3N~400	3N~400	3N~400	3N~400	3N~400
Operating Frequency	Hz	50/60	50/60	50/60	50/60	50/60
Operating Current <sup>3</sup>	A	7,7/4,5	7,7/4,5	7,7/4,5	12,3/7,2	15,3/9
Fuse Protection, On Site	A	10	10	10	10	10
Duty Types	ED	S3-%60	S3-%60	S3-%60	S3-%60	S3-%60
IP Protection Class	IP	54	54	54	54	54
Temperature Range <sup>4</sup>	°C	-20 +40 (+60)	-20 +40 (+60)	-20 +40 (+60)	-20 +40 (+60)	-20 +40 (+60)
Working Noise Level	dB (A)	< 70	< 70	< 70	< 70	< 70

## Application

Sectional Doors Cable Drum [mm] <sup>A</sup>	Type	DS-85-450-24		DS-85-600-15		DS-110-600-24		DS-110-800-24-HD		DS-110-1000-24-HD	
		kg	cm/sn	kg	cm/sn	kg	cm/sn	kg	cm/sn	kg	cm/sn
Sectional Doors Cable Drum [mm] <sup>A</sup>	F-160	516	20,1	688	12,6	688	20,1	--	--	--	--
	F-200	413	25,1	550	15,7	550	25,1	734	25,1	917	25,1

Roller Shutters Tube EN 10220 [mm] <sup>B</sup>	108,0	552	--	--	--	--
	114,3	527	703	--	--	--
	133,0	465	619	619	826	1032
	159,0	552	736	736	981	1226
	177,8	362	483	483	643	804
	193,7	336	447	447	597	746
	219,1	301	401	401	535	668
	244,5	--	363	363	484	605
	273,0	--	328	328	438	547
	298,5	--	--	303	403	504

Maximum suspended weight in kg

## DS-NON BALANCED SECTIONAL DOOR DRIVES

---

A safety brake antifall mechanism (parachute) which prevents free fall of the door just in case gear broken are built in gearbox.

1- Output shafts Ø25,0-Ø25,4-Ø30,0-Ø31,75-Ø40,0 mm etc. can be made upon request.

2- One cycle corresponds to two door movements (opening and closing). The specified values represent 10 revolutions of the drive shaft per movement and an even distribution is assumed. For other limit speed ranges or for heavily used doors, drag forces must be reduced. A motor with cooler and higher duty cycle should be selected. (Please ask)

3- Max. current in door drives can reach up to 4 times the rated operating current for limited times.

4- Allowable temperature -20°C.. +40°C (+60°C). When using the +40°C.. +60°C temperature range, half of the maximum movements per hour should be used.

↘ If frequency inverter drives are used, increasing the driving speed by 10% will cause a 5% decrease in drive torque. This should be considered when choosing a driver.

↘ In gearmotors powered at a frequency of 60Hz (and at the same voltage), multipliers are used for some performance figures: Output torque: 0.83 , and rotations in output: 1.2

### A- Driver Selection Table For Springless Doors

Using this table, the door drive can be determined easily and reliably.

The values in the table take into account safety reserve of 10%.

In some cases, the friction may be greater and these values should be taken into account when calculating.

For VL vertically raised doors, reduce weight by 20% more.

### B- Selection Of Suitable Drivers For Roller Shutters

To select the optimum drive solution, you will need the diameter of the winding shaft in mm and the suspended weight of the door in kg.

With the help of these parameters, the appropriate roller shutter drive can be determined easily and reliably using this table.

All indicated weights take into account a safety reserve of 20 % and a slat thickness of 25 mm.

In some cases, the friction may be greater and this condition should be taken into account when calculating.

For double-walled, thick or deep-section insulated lamellas, reduce the weight in the table by 20%. The highest load normally occurs after 1-2 rotations of the shutter.

Their extra friction and possible diameter changes due to over-winding, must be taken into account when calculating these values.

Special solutions can be offered upon request. Please contact us for requests in different speeds and powers.

# DIMENSIONS

## DS-50 WITH MK

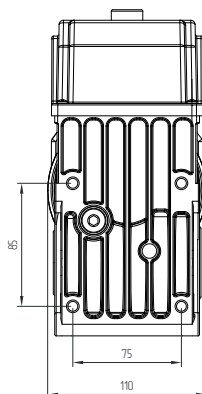
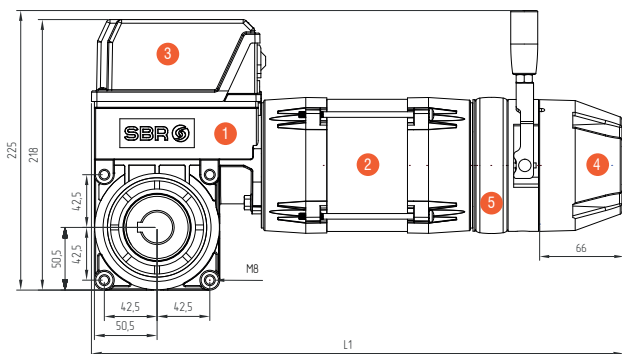

1	Gearbox
2	Motor
3	Limit Switch
4	Hand Crank MK
5	Brake

DS SERIES	L1
DS-50-140-20	410

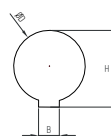
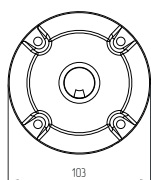
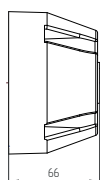

ØD	H	B
D25.4	28,4	6,35
D30.0	33,3	8,00
D31.75	34,7	6,35

## DS-50 WITH C2

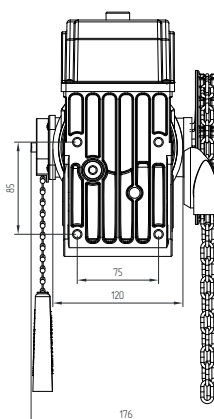
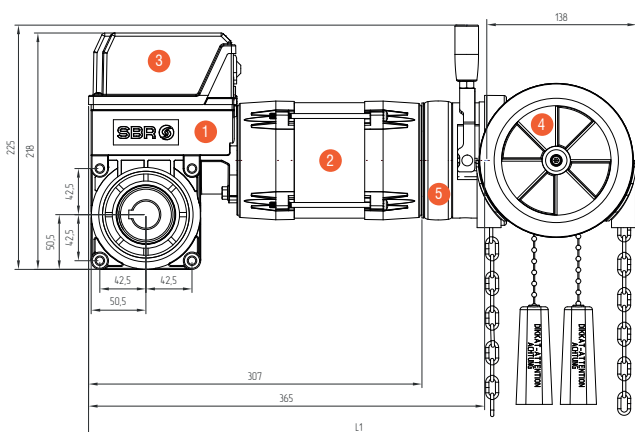

1	Gearbox
2	Motor
3	Limit Switch
4	Hand Crank C2
5	Brake

DS SERIES	L1
DS-50-140-20	463

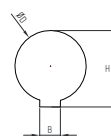
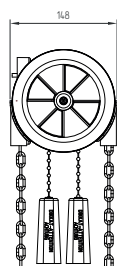
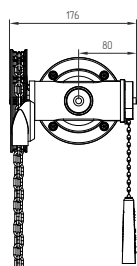

ØD	H	B
D25.4	28,4	6,35
D30.0	33,3	8,00
D31.75	34,7	6,35

# DIMENSIONS

## DS-63 WITH MK

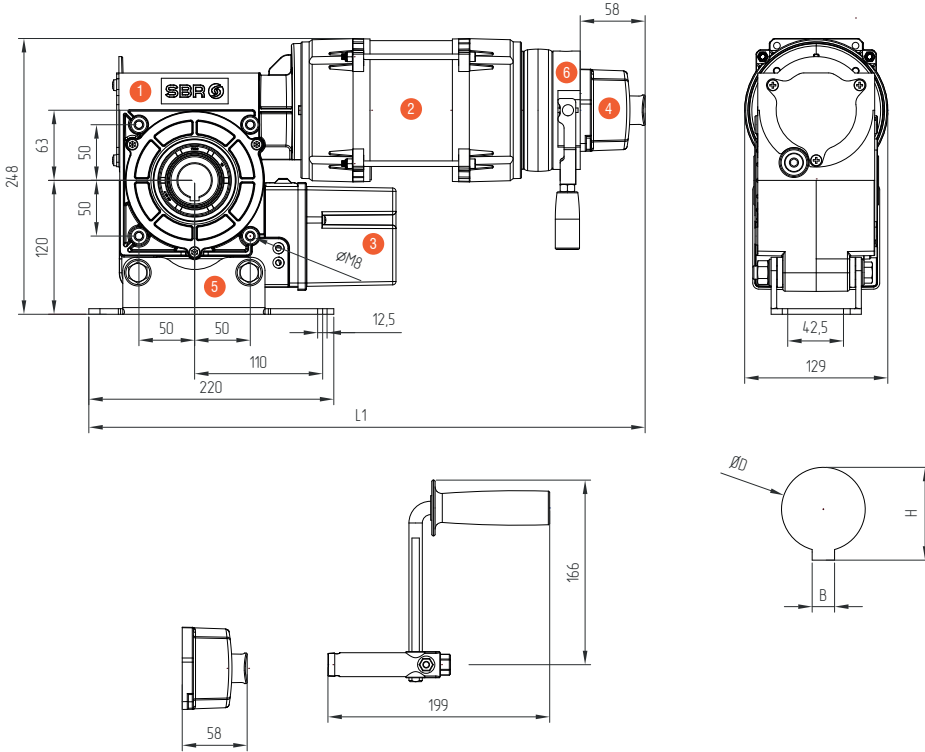

1	Gearbox
2	Motor
3	Limit Switch
4	Hand Crank MK
5	Floating Foot
6	Brake

DS SERIES	L1
DS-63-170-24	455
DS-63-200-19	455

ØD	H	B
D25.0	28,3	8,00
D25.4	28,4	6,35
D30.0	33,3	8,00
D31.75	34,7	6,35

## DS-63 WITH C2

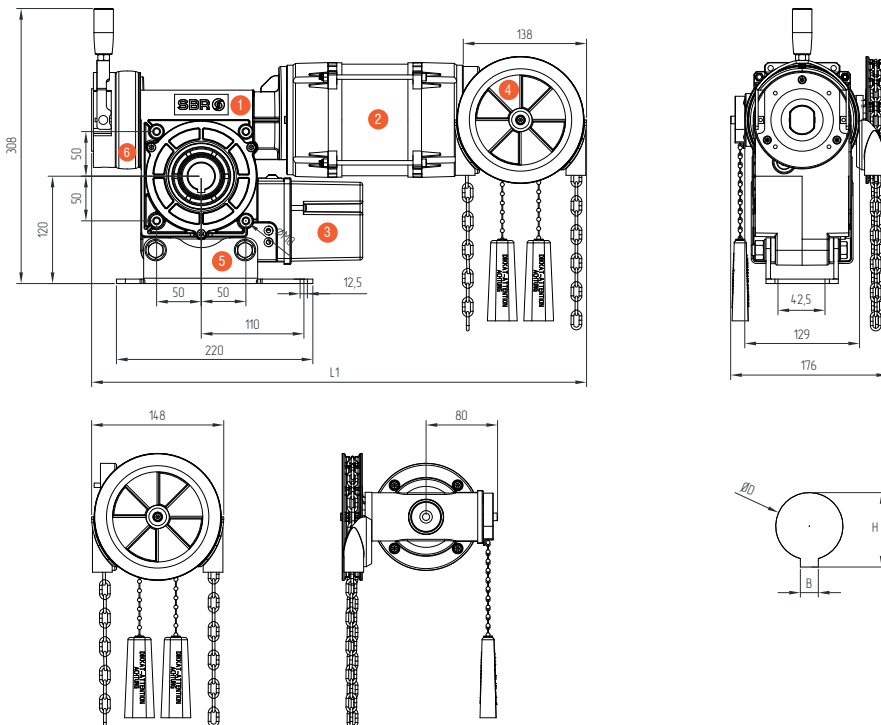

1	Gearbox
2	Motor
3	Limit Switch
4	Hand Crank C2
5	Floating Foot
6	Brake

DS SERIES	L1
DS-63-170-24	534
DS-63-200-19	534

ØD	H	B
D25.0	28,3	8,00
D25.4	28,4	6,35
D30.0	33,3	8,00
D31.75	34,7	6,35

# DIMENSIONS

## DS-85 WITH MK

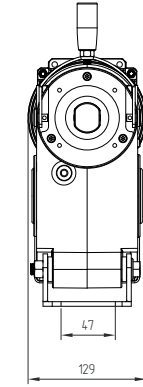
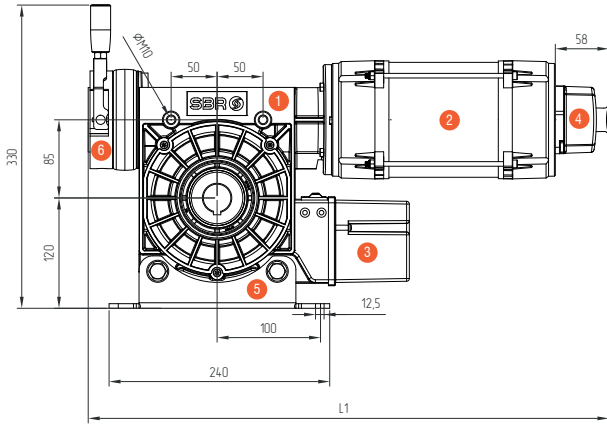

1	Gearbox
2	Motor
3	Limit Switch
4	Hand Crank MK
5	Floating Foot
6	Brake

DS SERIES	L1
DS-85-250-24	500
DS-85-350-24	520
DS-85-450-24	566
DS-85-550-15	520

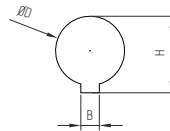
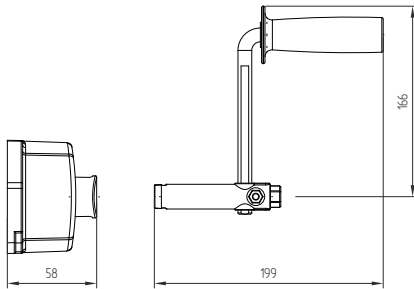

ØD	H	B
D30.0	33,3	8,00
D31.75	34,7	6,35
D40.0	43,3	12,00

## DS-85 WITH C2

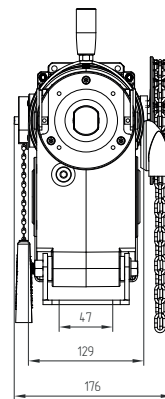
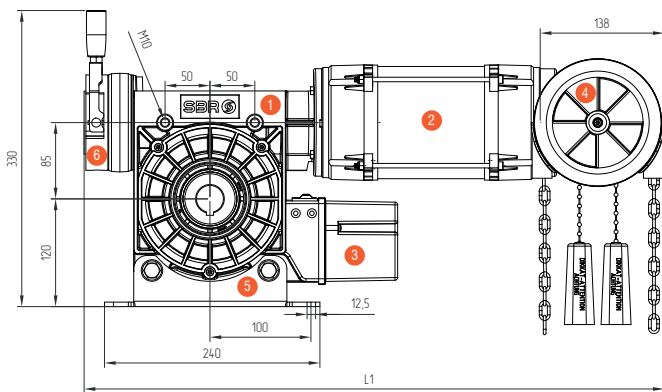

1	Gearbox
2	Motor
3	Limit Switch
4	Hand Crank C2
5	Floating Foot
6	Brake

DS SERIES	L1
DS-85-250-24	580
DS-85-350-24	600
DS-85-450-24	646
DS-85-550-15	600

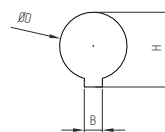
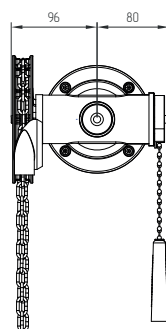
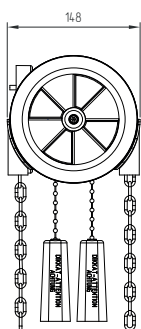

ØD	H	B
D30.0	33,3	8,00
D31.75	34,7	6,35
D40.0	43,3	12,00

# DIMENSIONS

## DS-110 WITH MK

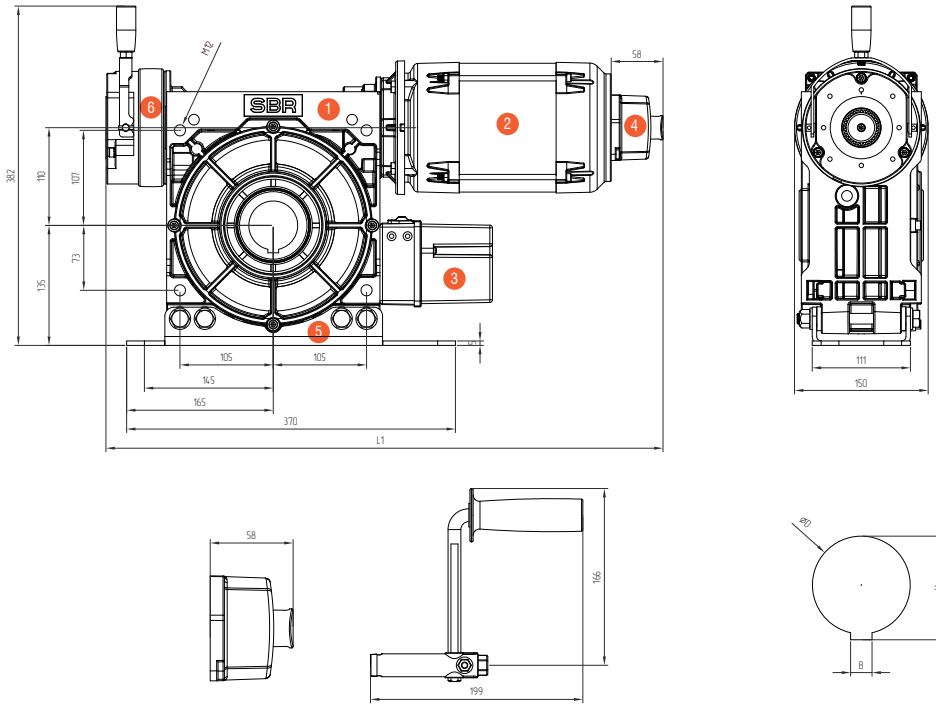

1	Gearbox
2	Motor
3	Limit Switch
4	Hand Crank MK
5	Floating Foot
6	Brake

DS SERIES	L1
DS-110-600-24	624
DS-110-750-24	627
DS-110-1000-24	627

ØD	H	B
D55.0	64,4	16,00

## DS-110 WITH C2

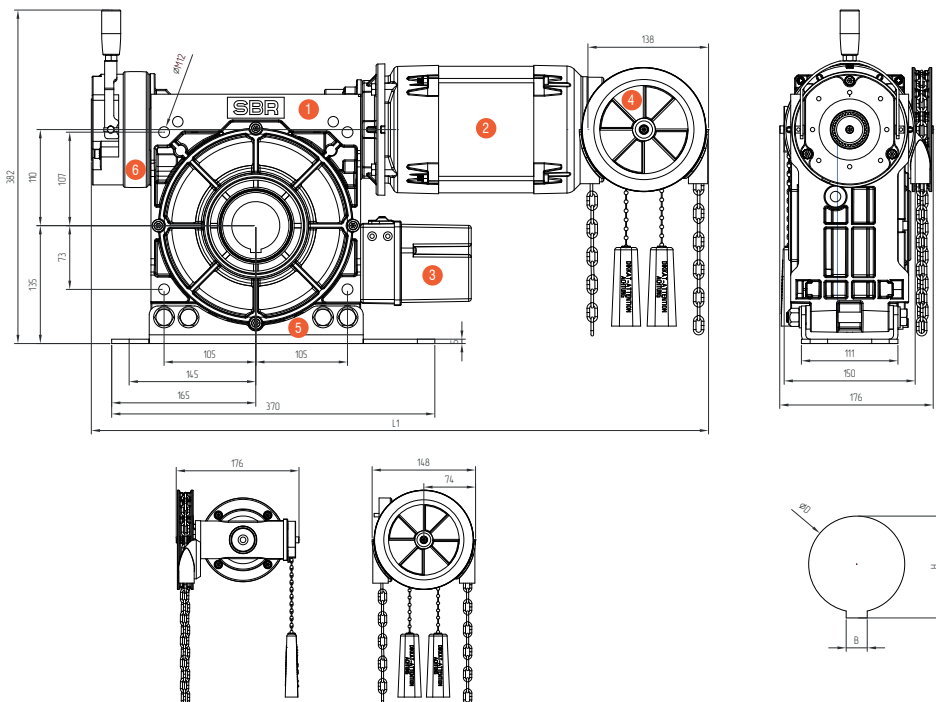

1	Gearbox
2	Motor
3	Limit Switch
4	Hand Crank C2
5	Floating Foot
6	Brake

DS SERIES	L1
DS-110-600-24	704
DS-110-750-24	707
DS-110-1000-24	707

ØD	H	B
D55.0	64,4	16,00